

PRODUCT CATALOGUE



KITO
HOISTS & CRANES

D E F Y G R A V I T Y

Defy Gravity

ABOUT KITO

Hoists are used by people. That's why the guiding principle behind everything we do is - and must remain - safety. Kito is committed to protecting you and your co-workers. Our dedication to safety and innovation remains as strong today as it was 70 years ago. It is at the very core of who we are and what we build. These values define our approach to product development, design and production.

Quality is the priority. Leading edge manufacturing techniques increase product quality and enhance performance. Every Kito hoist features the functionality and durability required by even the most demanding user.

At Kito, we believe that the safety and performance delivered by a hoist are not dependent on any one system or feature. Rather, it is the sum of these systems working together that results in the best hoist on the market today.

PROUDLY SERVING CANADA

KITO Canada Inc., as a wholly-owned subsidiary of KITO Corporation, is proud to offer a sales and service effort that matches the superior quality of the KITO product. Our sales staff are experienced in industrial and shop hoist applications, and we can answer your questions promptly and knowledgeably.

We can help you with selection, location, installation, and safety issues. And we can supply product quickly - even custom orders are usually ready to ship in a few days.

After the sale, we're still there to help you - with technical support, safety orientation seminars, and a comprehensive parts inventory.



TABLE OF CONTENTS

ELECTRIC CHAIN HOISTS

ER2 Series - Three Phase 220/440/575V	1 - 18
EFS Series - Single Phase 115V	19 - 20
ED Series - Single Phase 115V, High Speed, Portable	21 - 22



AIR POWERED CHAIN HOISTS

TCR Series	23 - 25
-------------------------	---------



MANUAL CHAIN HOISTS

CF Series - Aluminum Body	26
M3CB Series - Steel Body	27 - 30
CX Series - Ultra Compact	31

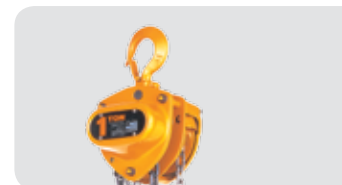

LEVER CHAIN HOISTS

LX Series - Pocket Sized	32
LSLB Series - Industrial Grade	33 - 34

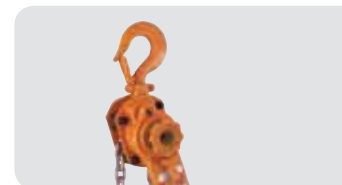

TROLLEYS

TS2 Series - Plain and Geared Trolleys	35
TMH Mini Trolley	35
MR2 Series - Motorized Trolleys	36



ER2 Series Electric Chain Hoists

1/8 to 20 metric tonne capacity, three phase (220/440/575V) for heavy industrial use



Engineered to perform in the industry's toughest applications and most extreme conditions, the ER2 Series Hoists feature advanced hoist technology, easy serviceability, and unmatched durability.

FEATURES

- DC-current electromagnetic brake with an electrical fail-safe design and 10 year / 2,000,000 cycle warranty
- Extreme Duty TEFC Motor with thermal overload protection and industry leading duty rating
- Slip clutch protects hoist against over-travel and over-load damage
- Durable upper / lower limit switch prevents over-lifting without increasing headroom
- Ergonomic push-button pendant equipped with a standard emergency stop button
- At rated capacity, load bearing parts are stressed to only 20% of their limit
- Grade 80, case hardened, nickel-plated load chain is abrasion and corrosion resistant
- Forged carbon steel hooks are engineered to open gradually and not fracture under excessive loads
- Standard count hour meter records the hoist starts and run time (hours) for maintenance records
- Quick-connect plugs allow for easy installation and maintenance
- 110 Volt pendant control is easily adapted to crane systems
- Tested to 125% of rated capacity

Duty Ratings	Single Speed	Adjustable 2-speed & Dual Speed
ASME Class	H4	H4
Max. Starts / hr	360	240 / 120
%ED	60	40 / 20
Short Time Rating	60 min	30 / 10 min

STANDARDS

- CSA Electrical Certification
- ASME B30.16 Safety Standard
- ASME HST-1 Performance Standard
- Grade 80, Case Hardened Chain
- IP55 Environmental Protection

OPTIONS

- VFD for adjustable 2-speed operation (Under the cover - 220 / 440V; Panel mount - 575V)
- Dual speed (575 volt) with mechanically interlocked electromagnetic contactors
- Ergonomic cylinder control for easy one-handed operation
- Weston style mechanical brake for applications where two holding brakes are required
- Canvas chain bag to keep chain clean and out of the way
- Plastic chain container for ultra-low headroom applications
- Steel chain container for long-lift applications
- Custom lift lengths to suit your requirements

MOUNTING OPTIONS

- Hook, Plain Trolley, or Geared Trolley for improved efficiency
- Single Speed/Dual Speed Motorized Trolley for improved load control
- Perpendicular to beam (standard), or parallel to beam for operation in tight spaces



ER2 Single-Speed Hoist - Hook Mount



220
VOLTS

440
VOLTS

575
VOLTS

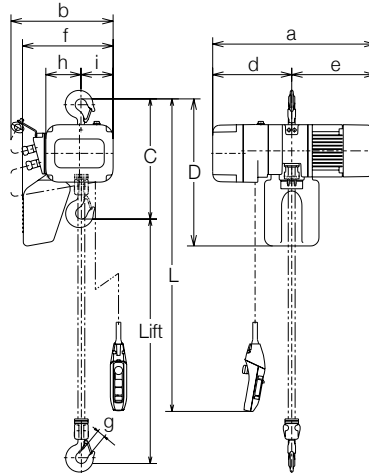

DIMENSIONS (mm)

Capacity (tonne)	Model	C	D	a	b	d	e	f	g	h	i
¼	ER2001H	350	430	478	321	219	259	260	27	99	93
¼	ER2003S	350	430	478	321	219	259	260	27	99	93
½	ER2005L	370	490	513	348	242	271	283	27	113	106
½	ER2005S	370	490	510	348	242	268	283	27	113	106
1	ER2010L	430	550	589	376	291	298	335	31	129	118
1	ER2010S	430	550	598	376	291	307	335	31	129	118
1½	ER2015S	510	630	646	427	308	338	384.5	34	160.5	137.5
2	ER2020L	575	630	646	427	308	338	384.5	39	160.5	137.5
2	ER2020S	590	630	703	427	347	356	384.5	39	160.5	137.5
2½	ER2025S	625	840	736	445	337	399	437.5	39	173.5	142.5
3	ER2030S	835	920	703	427	347	356	397	44	216	82
5	ER2050S	910	920	736	445	337	399	439.5	47	231.5	84.5

SPECIFICATIONS

Capacity (tonne)	Model	Lift Speed (ft/min)	Hoist Motor H.P.	Rated Current (amps)			Headroom (in)			Load Chain Code	Load Chain Falls	Ship Weight (lbs)	Weight per Additional 5 ft of Lift (lbs)
				220V	440V	575V	Hook Mount Only	Plain Trolley	Geared Trolley				
¼	ER2001H	55	0.75	3.4	1.7	1.4	13.8	15.6	16.3	KER2043	1	58	1.4
¼	ER2003S	36	0.75	3.4	1.7	1.4	13.8	15.6	16.3	KER2043	1	58	1.4
½	ER2005L	15	0.75	3.4	1.7	1.4	14.6	16.3	17.1	KER2060	1	70	2.7
½	ER2005S	29	1.2	4.8	2.5	1.8	14.6	16.3	17.1	KER2060	1	79	2.7
1	ER2010L	14	1.2	4.8	2.5	1.8	16.9	18.5	18.5	KER2077	1	101	4.5
1	ER2010S	28	2.4	8.6	4.2	3.3	16.9	18.5	18.5	KER2077	1	117	4.5
1½	ER2015S	18	2.4	8.6	4.2	3.3	20.1	22.4	22.4	KER2102	1	155	8
2	ER2020L	14	2.4	8.6	4.2	3.3	22.6	25	25	KER2102	1	157	8
2	ER2020S	28	4.7	16.4	7.9	6.2	23.2	25.6	25.6	KER2102	1	197	8
2½	ER2025S	22	4.7	16.4	7.9	6.2	24.6	26.8	26.8	KER2112	1	224	9.5
3	ER2030S	17	4.7	16.4	7.9	6.2	33	32.7	32.7	KER2102	2	228	16
5	ER2050S	11	4.7	16.4	7.9	6.2	35.8	35.4	35.4	KER2112	2	282	19

ER2 Single-Speed Hoist - Plain Trolley Mount

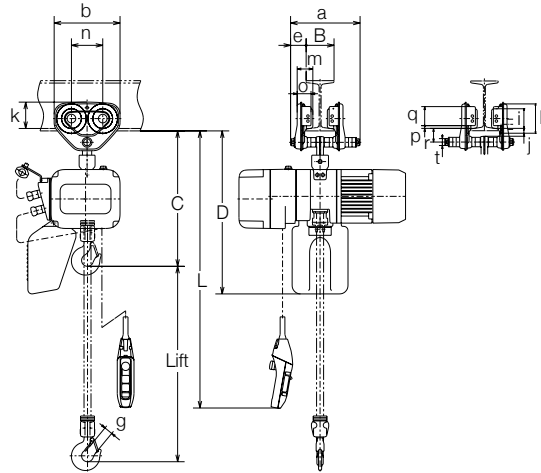

220
VOLTS

440
VOLTS

575
VOLTS

DIMENSIONS (mm)

Capacity (tonne)	Hoist Model	Trolley Model	C	D	a	b	e	g	h	i	j	k	m	n	o	p	q	r	t
1/8	ER2001H	TSP2005	395	470	204	182	46	27	82	60	21	76	47.5	84	42	10	54	38	22
1/4	ER2003S	TSP2005	395	470	204	182	46	27	82	60	21	76	47.5	84	42	10	54	38	22
1/2	ER2005L	TSP2005	415	530	204	182	46	27	82	60	21	76	47.5	84	42	10	54	38	22
1/2	ER2005S	TSP2005	415	530	204	182	46	27	82	60	21	76	47.5	84	42	10	54	38	22
1	ER2010L	TSP2010	470	590	249	236	56	31	106	71	28	95	56	112	50	10	69	50	25
1	ER2010S	TSP2010	470	590	249	236	56	31	106	71	28	95	56	112	50	10	69	50	25
1 1/2	ER2015S	TSP2020	570	690	300	280	69	34	127	85	34	112	71	131	63	10	83	62	32
2	ER2020L	TSP2020	635	690	300	280	69	39	127	85	34	112	71	131	63	10	83	62	32
2	ER2020S	TSP2020	650	690	300	280	69	39	127	85	34	112	71	131	63	10	83	62	32
2 1/2	ER2025S	TSP2030	680	890	320	324	79	39	148	100	36	134	80	152	74	10	102	68	36
3	ER2030S	TSP2030	830	910	320	324	79	44	148	100	36	134	80	152	74	10	102	68	36
5	ER2050S	TSP2050	900	910	297	400	53	47	169	118	46	144	81	178	70	10	104	88	54

SPECIFICATIONS

Capacity (tonne)	Hoist Model	Trolley Model	Lift Speed (ft/min)	Hoist Motor H.P.	Rated Current (amps)			Headroom (in) Plain Trolley Mount	Minimum Radius for a Curve (mm)	Load Chain Code	Load Chain Falls	Ship Weight (lbs)	Weight per Additional 5 ft of Lift (lbs)
					220V	440V	575V						
1/8	ER2001H	TSP2005	55	0.75	3.4	1.7	1.4	15.6	1100	KER2043	1	70	1.4
1/4	ER2003S	TSP2005	36	0.75	3.4	1.7	1.4	15.6	1100	KER2043	1	70	1.4
1/2	ER2005L	TSP2005	15	0.75	3.4	1.7	1.4	16.3	1100	KER2060	1	81	2.7
1/2	ER2005S	TSP2005	29	1.2	4.8	2.5	1.8	16.3	1100	KER2060	1	89	2.7
1	ER2010L	TSP2010	14	1.2	4.8	2.5	1.8	18.5	1300	KER2077	1	122	4.5
1	ER2010S	TSP2010	28	2.4	8.6	4.2	3.3	18.5	1300	KER2077	1	137	4.5
1 1/2	ER2015S	TSP2020	18	2.4	8.6	4.2	3.3	22.4	1500	KER2102	1	190	8
2	ER2020L	TSP2020	14	2.4	8.6	4.2	3.3	25.0	1500	KER2102	1	192	8
2	ER2020S	TSP2020	28	4.7	16.4	7.9	6.2	25.6	1500	KER2102	1	232	8
2 1/2	ER2025S	TSP2030	22	4.7	16.4	7.9	6.2	26.8	1700	KER2112	1	278	9.5
3	ER2030S	TSP2030	17	4.7	16.4	7.9	6.2	32.7	1700	KER2102	2	279	16
5	ER2050S	TSP2050	11	4.7	16.4	7.9	6.2	35.4	2300	KER2112	2	405	16

ER2 Single-Speed Hoist - Geared Trolley Mount



220
VOLTS

440
VOLTS

575
VOLTS

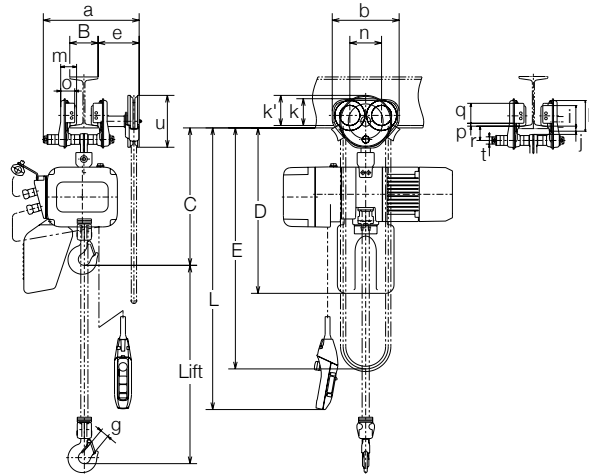

DIMENSIONS (mm)

Capacity (tonne)	Hoist Model	Trolley Model	C	D	a	b	e	g	h	i	j	k	k'	m	n	o	p	q	r	t	u
1/8	ER2001H	TSG2010	415	490	345	236	152	27	106	71	28	95	107	56	112	50	10	69	50	25	183
1/4	ER2003S	TSG2010	415	490	345	236	152	27	106	71	28	95	107	56	112	50	10	69	50	25	183
1/2	ER2005L	TSG2010	435	550	345	236	152	27	106	71	28	95	107	56	112	50	10	69	50	25	183
1/2	ER2005S	TSG2010	435	550	345	236	152	27	106	71	28	95	107	56	112	50	10	69	50	25	183
1	ER2010L	TSG2010	470	590	345	236	152	31	106	71	28	95	107	56	112	50	10	69	50	25	183
1	ER2010S	TSG2010	470	590	345	236	152	31	106	71	28	95	107	56	112	50	10	69	50	25	183
1 1/2	ER2015S	TSG2020	570	690	385	280	154	34	127	85	34	112	109	71	131	63	10	83	62	32	183
2	ER2020L	TSG2020	635	690	385	280	154	39	127	85	34	112	109	71	131	63	10	83	62	32	183
2	ER2020S	TSG2020	650	690	385	280	154	39	127	85	34	112	109	71	131	63	10	83	62	32	183
2 1/2	ER2025S	TSG2030	680	890	398	324	157	39	148	100	36	134	115	80	152	74	10	102	68	36	183
3	ER2030S	TSG2030	830	910	398	324	157	44	148	100	36	134	115	80	152	74	10	102	68	36	183
5	ER2050S	TSG2050	900	910	401	400	156	47	169	118	46	144	131	81	178	70	10	104	88	54	183

SPECIFICATIONS

Capacity (tonne)	Hoist Model	Trolley Model	Lift Speed (ft/min)	Hoist Motor H.P.	Rated Current (amps)			Headroom (in) Geared Trolley Mount	Minimum Radius for a Curve (mm)	Load Chain Code	Load Chain Falls	Ship Weight (lbs)	Weight per Additional 5 ft of Lift (lbs)
					220V	440V	575V						
1/8	ER2001H	TSG2010	55	0.75	3.4	1.7	1.4	16.3	1300	KER2043	1	87	1.4
1/4	ER2003S	TSG2010	36	0.75	3.4	1.7	1.4	16.3	1300	KER2043	1	87	1.4
1/2	ER2005L	TSG2010	15	0.75	3.4	1.7	1.4	17.1	1300	KER2060	1	98	2.7
1/2	ER2005S	TSG2010	29	1.2	4.8	2.5	1.8	17.1	1300	KER2060	1	106	2.7
1	ER2010L	TSG2010	14	1.2	4.8	2.5	1.8	18.5	1300	KER2077	1	131	4.5
1	ER2010S	TSG2010	28	2.4	8.6	4.2	3.3	18.5	1300	KER2077	1	146	4.5
1 1/2	ER2015S	TSG2020	18	2.4	8.6	4.2	3.3	22.4	1500	KER2102	1	201	8
2	ER2020L	TSG2020	14	2.4	8.6	4.2	3.3	25	1500	KER2102	1	203	8
2	ER2020S	TSG2020	28	4.7	16.4	7.9	6.2	25.6	1500	KER2102	1	243	8
2 1/2	ER2025S	TSG2030	22	4.7	16.4	7.9	6.2	26.8	1700	KER2112	1	287	9.5
3	ER2030S	TSG2030	17	4.7	16.4	7.9	6.2	32.7	1700	KER2102	2	288	16
5	ER2050S	TSG2050	11	4.7	16.4	7.9	6.2	35.4	2300	KER2112	2	463	16

ER2 Single-Speed Hoist - Single-Speed Motorized Trolley

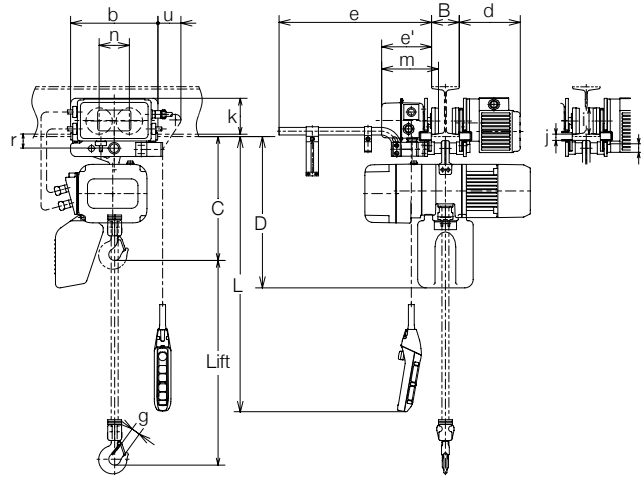

220
VOLTS

440
VOLTS

575
VOLTS

DIMENSIONS (mm)

Capacity (tonne)	Hoist & Trolley Model	C	D	b	d	e	e'	g	i	j	k	m	n	r	t	u
1/8	ER2M001H	375	450	315	220	515	179	27	95	22	130	205	109	51	31	83
1/4	ER2M003S	375	450	315	220	515	179	27	95	22	130	205	109	51	31	83
1/2	ER2M005L	395	510	315	220	515	179	27	95	22	130	205	109	51	31	83
1/2	ER2M005S	395	510	315	220	515	179	27	95	22	130	205	109	51	31	83
1	ER2M010L	435	550	315	220	515	179	31	95	22	130	205	109	51	31	83
1	ER2M010S	435	550	315	220	515	179	31	95	22	130	205	109	51	31	83
1 1/2	ER2M015S	505	630	325	225	520	184	34	110	27	125	212	118	60	36	76
2	ER2M020L	570	630	325	225	520	184	39	110	27	125	212	118	60	36	76
2	ER2M020S	585	630	325	225	520	184	39	110	27	125	212	118	60	36	76
2 1/2	ER2M025S	620	830	340	226	521	186	39	125	29	131	215	132	68	43	70
3	ER2M030S	815	900	340	226	521	186	44	125	29	131	215	132	68	43	70
5	ER2M050S	900	910	400	281	528	192	47	140	44	145	233	150	86	54	56

SPECIFICATIONS

Capacity (tonne)	Hoist & Trolley Model	Speed (ft/min)		Hoist Motor H.P.	Rated Current (amps)			Headroom (in) Lug Mount Only	Minimum Radius for a Curve (mm)	Load Chain Code	Load Chain Falls	Ship Weight (lbs)	Weight per Additional 5 ft of Lift (lbs)
		Hoist Lifting	Trolley Traversing		220V	440V	575V						
1/8	ER2M001H	55	40 or 80	0.75	6.6	3.3	2.5	14.8	800	KER2043	1	126	1.4
1/4	ER2M003S	36	40 or 80	0.75	6.6	3.3	2.5	14.8	800	KER2043	1	126	1.4
1/2	ER2M005L	15	40 or 80	0.75	6.6	3.3	2.5	15.6	800	KER2060	1	138	2.7
1/2	ER2M005S	29	40 or 80	1.2	8	4.1	2.9	156	800	KER2060	1	147	2.7
1	ER2M010L	14	40 or 80	1.2	8	4.1	2.9	17	800	KER2077	1	167	4.5
1	ER2M010S	28	40 or 80	2.4	11.8	5.8	4.4	17	800	KER2077	1	183	4.5
1 1/2	ER2M015S	18	40 or 80	2.4	11.8	5.8	4.4	20	800	KER2102	1	238	8
2	ER2M020L	14	40 or 80	2.4	11.8	5.8	4.4	22	800	KER2102	1	241	8
2	ER2M020S	28	40 or 80	4.7	19.6	9.5	7.3	23	800	KER2102	1	280	8
2 1/2	ER2M025S	22	40 or 80	4.7	19.6	9.5	7.3	24.4	1000	KER2112	1	329	9.5
3	ER2M030S	17	40 or 80	4.7	19.6	9.5	7.3	30	1000	KER2102	2	334	16
5	ER2M050S	11	40 or 80	4.7	21.5	10.4	8	33	1800	KER2112	2	436	19

ER2 Large Capacity - Single-Speed - Hook Mount

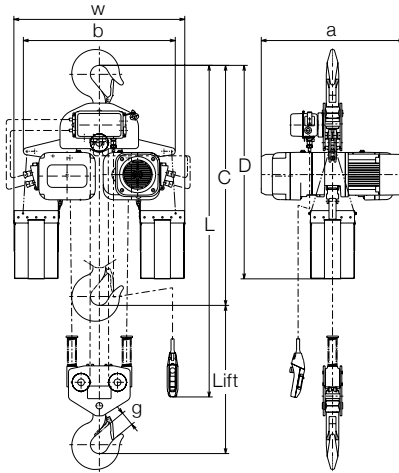

220
VOLTS

440
VOLTS

575
VOLTS

DIMENSIONS (mm)

Capacity (tonne)	Model	C	D	a	b	w	g
7½	ER2075S	----	----	----	----	----	----
10	ER2100L	----	----	----	----	----	----
10	ER2100S	1370	1210	798	849	956	80
15	ER2150S	1595	1520	798	1022	1129	86
20	ER2200S	1710	1600	798	1198	1305	102

SPECIFICATIONS

Capacity (tonne)	Model	Lift Speed (ft/min)	Hoist Motor H.P.	Rated Current (amps)			Headroom (in)			Load Chain Code	Load Chain Falls	Ship Weight (lbs)	Weight per Additional 5 ft of Lift (lbs)
				220V	440V	575V	Hook Mount Only	Plain Trolley	Geared Trolley				
7½	ER2075S	----	----	----	----	----	----	45.9	45.9	----	----	----	----
10	ER2100L	----	----	----	----	----	----	46.5	46.5	----	----	----	----
10	ER2100S	11	4.7 x 2	16.4 x 2	7.9 x 2	6.2 x 2	53.9	46.5	46.5	KER2112	4	668	38
15	ER2150S	7.5	4.7 x 2	16.4 x 2	7.9 x 2	6.2 x 2	62.8	----	54.6	KER2112	6	891	57
20	ER2200S	5.5	4.7 x 2	16.4 x 2	7.9 x 2	6.2 x 2	67.3	----	53	KER2112	8	1049	76

ER2 Large Capacity - Single-Speed - Geared Trolley



220
VOLTS

440
VOLTS

575
VOLTS

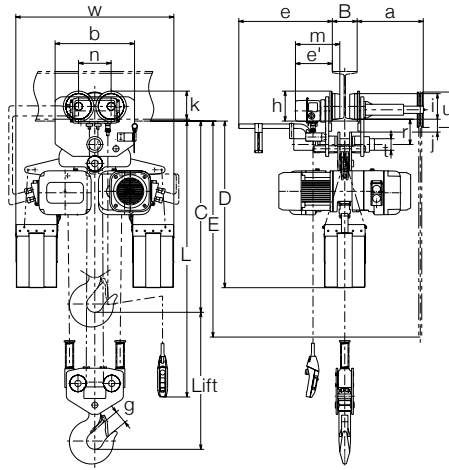

DIMENSIONS (mm)

Capacity (tonne)	Hoist Model	Trolley Model	C	D	a	b	e	e'	g	h	i	j	k	m	n	r	t	u	w
7½	ER2075S	TSG2100	1165	1230	372	480	531	----	61	185	155	87	171	----	196.5	153	70	214	662
10	ER2100L	TSG2100	1180	1210	372	480	531	----	80	185	155	77	171	----	196.5	153	70	214	718
10	ER2100S	TSG2100	1180	1020	372	480	531	223	80	185	155	77	171	269	196.5	153	70	214	956
15	ER2150S	TSG2200	1310	1230	1012	1000	531	223	86	185	155	82	171	269	520	153	70	214	1129
20	ER2200S	TSG2200	1345	1230	1012	1000	531	223	102	185	155	77	171	269	520	153	70	214	1305

SPECIFICATIONS

Capacity (tonne)	Hoist Model	Trolley Model	Lift Speed (ft/min)	Hoist Motor H.P.	Rated Current (amps)			Headroom (in) Geared Trolley Mount	Minimum Radius for a Curve (mm)	Load Chain Code	Load Chain Falls	Ship Weight (lbs)	Weight per Additional 5 ft of Lift (lbs)
					220V	440V	575V						
7½	ER2075S	TSG2100	7.5	4.7	16.4	7.9	6.2	45.9	3000	KER2112	3	662	27.5
10	ER2100L	TSG2100	5.5	4.7	16.4	7.9	6.2	46.5	3000	KER2112	4	917	37
10	ER2100S	TSG2100	11	4.7 x 2	16.4 x 2	7.9 x 2	6.2 x 2	46.5	3000	KER2112	4	968	37
15	ER2150S	TSG2200	7.5	4.7 x 2	16.4 x 2	7.9 x 2	6.2 x 2	54.6	3000	KER2112	6	1331	57
20	ER2200S	TSG2200	5.5	4.7 x 2	16.4 x 2	7.9 x 2	6.2 x 2	53.0	3000	KER2112	8	1489	80.5

ER2 Large Capacity - Single-Speed - Motorized Trolley



220
VOLTS

440
VOLTS

575
VOLTS

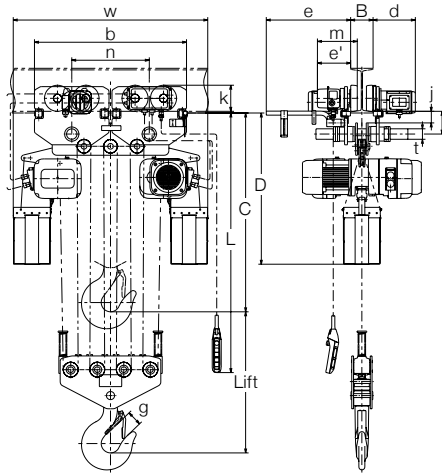

DIMENSIONS (mm)

Capacity (tonne)	Hoist & Trolley Model	C	D	b	e	e'	g	j	k	m	n	r	t	w
7½	ER2M075S	1165	1230	500	531	223	61	87	175	268	191	153	70	672
10	ER2M100L	1180	1210	500	531	223	80	77	175	268	191	153	70	728
10	ER2M100S	1180	1020	500	531	223	80	77	175	268	191	520	70	956
15	ER2M150S	1310	1230	1020	531	223	86	82	175	268	520	520	70	1129
20	ER2M200S	1345	1230	1020	531	223	102	77	175	268	520	520	70	1305

SPECIFICATIONS

Capacity (tonne)	Hoist & Trolley Model	Speed (ft/min)		Hoist Motor H.P.	Rated Current (amps)			Headroom (in) Lug Mount Only	Minimum Radius for a Curve (mm)	Load Chain Code	Load Chain Falls	Ship Weight (lbs)	Weight per Additional 5 ft of Lift (lbs)
		Hoist Lifting	Trolley Traversing		220V	440V	575V						
7½	ER2M075S	7.5	40 or 80	4.7	21.5	10.4	8	45.9	2500	KER2112	3	624	27.5
10	ER2M100L	5.5	40 or 80	4.7	21.5	10.4	8	46.5	2500	KER2112	4	833	38
10	ER2M100S	11	40 or 80	4.7 x 2	37.9	18.3	14.2	46.5	2500	KER2112	4	880	38
15	ER2M150S	7.5	40 or 80	4.7 x 2	43	20.8	16	51.6	----	KER2112	6	1259	57
20	ER2M200S	5.5	40 or 80	4.7 x 2	43	20.8	16	53.0	----	KER2112	8	1482	76

ER2 Adjustable 2-Speed Hoist - Hook Mount



220
VOLTS

440
VOLTS

VFD
EQUIPPED

DIMENSIONS (mm)

Capacity (tonne)	Model	C	D	a	b	d	e	f	g	h	i
Ergonomic Cylinder Control for easy one handed operation											
1/8	ER2C001IH	1065	490	535	345	276	259	284	27	99	117
1/4	ER2C003IS	1065	490	535	345	276	259	284	27	99	117
Two Button Push Button Pendant Control (110V)											
1/8	ER2001IH	350	430	535	345	276	259	284	27	99	117
1/4	ER2003IS	350	430	535	345	276	259	284	27	99	117
1/2	ER2005IL	370	490	571	348	300	271	283	27	113	106
1/2	ER2005IS	370	490	568	348	300	268	283	27	113	106
1	ER2010IL	430	550	614	376	316	298	335	31	129	118
1	ER2010IS	430	550	623	376	316	307	335	31	129	118
1 1/2	ER2015IS	510	630	710	427	372	338	384.5	34	160.5	137.5
2	ER2020IL	575	630	710	427	372	338	384.5	39	160.5	137.5
2	ER2020IS	590	630	767	427	411	356	384.5	39	160.5	137.5
2 1/2	ER2025IS	625	840	800	445	401	399	437.5	39	173.5	142.5
3	ER2030IS	785	920	767	427	411	356	397	44	216	82
5	ER2050IS	910	920	800	445	401	399	439.5	47	231.5	84.5

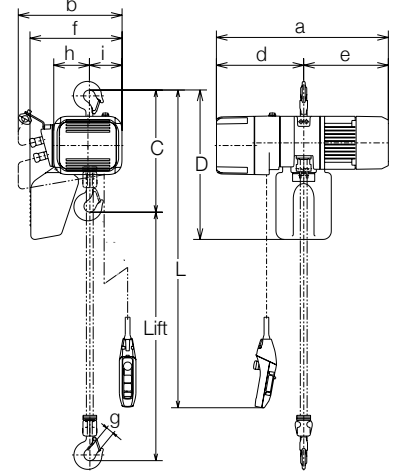

SPECIFICATIONS

Capacity (tonne)	Model	Standard Lift (ft)	Lift Speed (ft/min)			Hoist Motor H.P.	Rated Current (amps)		Headroom (in)			Load Chain Code	Load Chain Falls	Ship Weight (lbs)	Weight per Additional 5 ft of Lift (lbs)
			Preset (6:1)	Max	Min		220V	440V	Hook Mount Only	Plain Trolley	Geared Trolley				
Ergonomic Cylinder Control for easy one handed operation															
1/8	ER2C001IH	6 (max)	55/9	55	4.6	0.75	3.6	1.8	42	43.8	44.5	KER2043	1	64	1.4
1/4	ER2C003IS	6 (max)	36/6	36	3.0	0.75	3.6	1.8	42	43.8	44.5	KER2043	1	64	1.4
Two Button Push Button Pendant Control (110V)															
1/8	ER2001IH	10	55/9	55	4.6	0.75	3.6	1.8	13.8	15.6	16.3	KER2043	1	58	1.4
1/4	ER2003IS	10	36/6	36	3.0	0.75	3.6	1.8	13.8	15.6	16.3	KER2043	1	58	1.4
1/2	ER2005IL	10	15/2.5	15	1.3	0.75	3.6	1.8	14.6	16.3	17.1	KER2060	1	68	2.7
1/2	ER2005IS	10	28/5	29	2.4	1.2	5.1	2.7	14.6	16.3	17.1	KER2060	1	77	2.7
1	ER2010IL	10	14/2.5	14	1.2	1.2	5.1	2.7	16.9	18.5	18.5	KER2077	1	97	4.5
1	ER2010IS	10	27/4.5	28	2.3	2.4	9.1	4.5	16.9	18.5	18.5	KER2077	1	112	4.5
1 1/2	ER2015IS	10	17/3	18	1.5	2.4	9.1	4.5	20.1	22.4	22.4	KER2102	1	155	8
2	ER2020IL	10	14/2.5	14	1.2	2.4	9.1	4.5	27.8	25.0	25	KER2102	1	157	8
2	ER2020IS	10	27/4.5	28	2.3	4.7	17.3	8.3	23.2	25.6	25.6	KER2102	1	192	8
2 1/2	ER2025IS	10	22/3.5	22	1.8	4.7	17.3	8.3	24.6	26.8	26.8	KER2112	1	215	9.5
3	ER2030IS	10	17/3	17	1.4	4.7	17.3	8.3	31	32.7	32.7	KER2102	2	224	16
5	ER2050IS	10	11/2	11	0.9	4.7	17.3	8.3	33.5	35.4	35.4	KER2112	2	274	19

ER2 Dual Speed Hoist - Hook Mount



575
VOLTS

DIMENSIONS (mm)

Capacity (tonne)	Model	C	D	a	b	d	e	f	g	h	i
Ergonomic Cylinder Control for easy one handed operation											
1/8	ER2C001HD	1065	490	478	321	219	259	260	27	99	93
1/4	ER2C003SD	1065	490	478	321	219	259	260	27	99	93
Two Button Push Button Pendant Control (110V)											
1/8	ER2001HD	350	430	478	321	219	259	260	27	99	117
1/4	ER2003SD	350	430	478	321	219	259	260	27	99	117
1/2	ER2005LD	370	490	513	348	242	271	283	27	113	106
1/2	ER2005SD	370	490	533	348	242	291	283	27	113	106
1	ER2010LD	430	550	589	376	291	298	335	31	129	118
1	ER2010SD	430	550	615	376	291	324	335	31	129	118
1 1/2	ER2015SD	510	630	646	427	308	338	384.5	34	160.5	137.5
2	ER2020LD	575	630	646	427	308	338	384.5	39	160.5	137.5
2	ER2020SD	590	630	737	427	347	390	384.5	39	160.5	137.5
2 1/2	ER2025SD	625	840	736	445	337	399	437.5	39	173.5	142.5
3	ER2030SD	785	920	737	427	347	390	397	44	216	82
5	ER2050SD	910	920	736	445	337	399	439	47	231.5	84.5

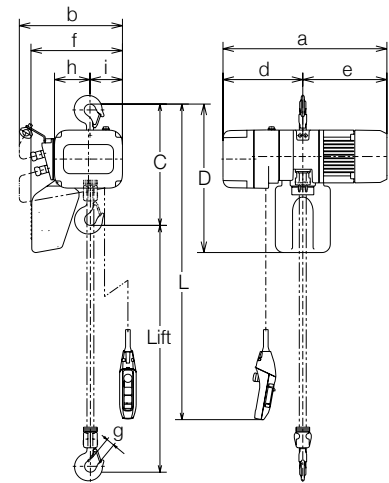

SPECIFICATIONS

Capacity (tonne)	Model	Standard Lift (ft)	Lift Speed (ft/min)	Hoist Motor H.P.	Rated Current 575V (amps)	Headroom (in)			Load Chain Code	Load Chain Falls	Ship Weight (lbs)	Weight per Additional 5 ft of Lift (lbs)
						Hook Mount Only	Plain Trolley	Geared Trolley				
Ergonomic Cylinder Control for easy one handed operation												
1/8	ER2C001HD	6 (max)	56/14	0.7/0.2	1.3/0.8	42	43.8	44.5	KER2043	1	74	1.4
1/4	ER2C003SD	6 (max)	28/7	0.7/0.2	1.3/0.8	42	43.8	44.5	KER2043	1	74	1.4
Two Button Push Button Pendant Control (110V)												
1/8	ER2001HD	10	57/14	0.7/0.2	1.4/0.9	13.8	15.6	16.3	KER2043	1	68	1.4
1/4	ER2003SD	10	28/7	0.7/0.2	1.4/0.9	13.8	15.6	16.3	KER2043	1	68	1.4
1/2	ER2005LD	10	14/4	0.7/0.2	1.4/0.9	14.6	16.3	17.1	KER2060	1	83	2.7
1/2	ER2005SD	10	29/7	1.2/0.3	1.7/1.4	14.6	16.3	17.1	KER2060	1	95	2.7
1	ER2010LD	10	14/4	1.2/0.3	1.7/1.4	17	18.5	18.5	KER2077	1	123	4.5
1	ER2010SD	10	29/7	2.4/0.6	3.2/2.0	17	18.5	18.5	KER2077	1	128	4.5
1 1/2	ER2015SD	10	20/5	2.4/0.6	3.2/2.0	20	22.4	22.4	KER2102	1	163	8
2	ER2020LD	10	15/4	2.4/0.6	3.2/2.0	22.6	25.0	25	KER2102	1	167	8
2	ER2020SD	10	28/6	4.7/1.2	6.0/3.4	23	25.6	25.6	KER2102	1	213	8
2 1/2	ER2025SD	10	22/5	4.7/1.2	6.0/3.4	24.6	26.8	26.8	KER2112	1	238	9.5
3	ER2030SD	10	18/4	4.7/1.2	6.0/3.4	31	32.7	32.7	KER2102	2	249	16
5	ER2050SD	10	11/2	4.7/1.2	6.0/3.4	33.5	35.4	35.4	KER2112	2	295	19

ER2 Adjustable 2-Speed Hoist - Plain Trolley Mount

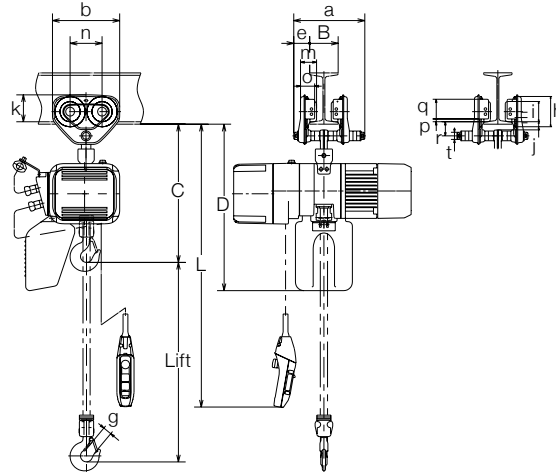

220
VOLTS

440
VOLTS

VFD
EQUIPPED

DIMENSIONS (mm)

Capacity (tonne)	Hoist Model	Trolley Model	C	D	a	b	e	g	h	i	j	k	m	n	o	p	q	r	t
1/8	ER2001IH	TSP2005	395	470	204	182	46	27	82	60	21	76	47.5	84	42	10	54	38	22
1/4	ER2003IS	TSP2005	395	470	204	182	46	27	82	60	21	76	47.5	84	42	10	54	38	22
1/2	ER2005IL	TSP2005	415	530	204	182	46	27	82	60	21	76	47.5	84	42	10	54	38	22
1/2	ER2005IS	TSP2005	415	530	204	182	46	27	82	60	21	76	47.5	84	42	10	54	38	22
1	ER2010IL	TSP2010	470	590	249	236	56	31	106	71	28	95	56	112	50	10	69	50	25
1	ER2010IS	TSP2010	470	590	249	236	56	31	106	71	28	95	56	112	50	10	69	50	25
1 1/2	ER2015IS	TSP2020	570	690	300	280	69	34	127	85	34	112	71	131	63	10	83	62	32
2	ER2020IL	TSP2020	635	690	300	280	69	39	127	85	34	112	71	131	63	10	83	62	32
2	ER2020IS	TSP2020	650	690	300	280	69	39	127	85	34	112	71	131	63	10	83	62	32
2 1/2	ER2025IS	TSP2030	680	890	320	324	79	39	148	100	36	134	80	152	74	10	102	68	36
3	ER2030IS	TSP2030	780	910	320	324	79	44	148	100	36	134	80	152	74	10	102	68	36
5	ER2050IS	TSP2050	900	910	297	400	53	47	169	118	46	144	81	178	70	10	104	88	54

SPECIFICATIONS

Capacity (tonne)	Hoist Model	Trolley Model	Lift Speed (ft/min)			Hoist Motor H.P.	Rated Current (amps)		Headroom (in) Plain Trolley Mount	Minimum Radius for a Curve (mm)	Load Chain Code	Load Chain Falls	Ship Weight (lbs)	Weight per Additional 5 ft of Lift (lbs)
			Preset (6:1)	Max	Min		220V	440V						
1/8	ER2001IH	TSP2005	55/9	55	4.6	0.75	3.6	1.8	15.6	1100	KER2043	1	70	1.4
1/4	ER2003IS	TSP2005	36/6	36	3.0	0.75	3.6	1.8	15.6	1100	KER2043	1	70	1.4
1/2	ER2005IL	TSP2005	15/2.5	15	1.3	0.75	3.6	1.8	16.3	1100	KER2060	1	78	2.7
1/2	ER2005IS	TSP2005	28/5	28	2.4	1.2	5.1	2.7	16.3	1100	KER2060	1	87	2.7
1	ER2010IL	TSP2010	14/2.5	14	1.2	1.2	5.1	2.7	18.5	1300	KER2077	1	117	4.5
1	ER2010IS	TSP2010	27/4.5	27	2.3	2.4	9.1	4.5	18.5	1300	KER2077	1	133	4.5
1 1/2	ER2015IS	TSP2020	17/3	17	1.5	2.4	9.1	4.5	22.4	1500	KER2102	1	190	8
2	ER2020IL	TSP2020	14/2.5	14	1.2	2.4	9.1	4.5	25.0	1500	KER2102	1	192	8
2	ER2020IS	TSP2020	27/4.5	27	2.3	4.7	17.3	8.3	25.6	1500	KER2102	1	227	8
2 1/2	ER2025IS	TSP2030	22/3.5	22	1.8	4.7	17.3	8.3	26.8	1700	KER2112	1	269	9.5
3	ER2030IS	TSP2030	17/3	17	1.4	4.7	17.3	8.3	32.7	1700	KER2102	2	280	16
5	ER2050IS	TSP2050	11/2	11	0.9	4.7	17.3	8.3	35.4	2300	KER2112	2	396	19

ER2 Dual Speed Hoist - Plain Trolley Mount



575
VOLTS

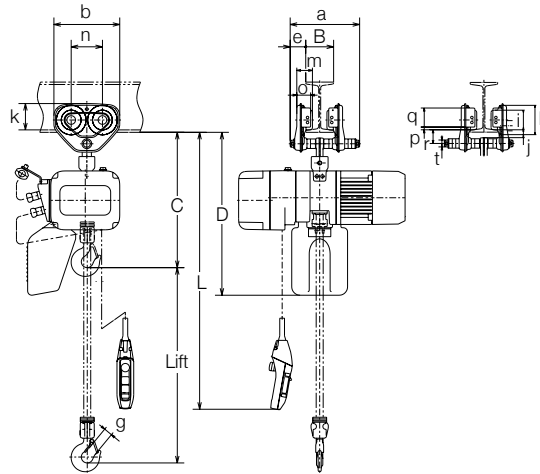

DIMENSIONS (mm)

Capacity (tonne)	Hoist Model	Trolley Model	C	D	a	b	e	g	h	i	j	k	m	n	o	p	q	r	t
¼	ER2001HD	TSP2005	395	470	204	182	46	27	82	60	21	76	47.5	84	42	10	54	38	22
¼	ER2003SD	TSP2005	395	470	204	182	46	27	82	60	21	76	47.5	84	42	10	54	38	22
½	ER2005LD	TSP2005	415	530	204	182	46	27	82	60	21	76	47.5	84	42	10	54	38	22
½	ER2005SD	TSP2005	415	530	204	182	46	27	82	60	21	76	47.5	84	42	10	54	38	22
1	ER2010LD	TSP2010	470	590	249	236	56	31	106	71	28	95	56	112	50	10	69	50	25
1	ER2010SD	TSP2010	470	590	249	236	56	31	106	71	28	95	56	112	50	10	69	50	25
1½	ER2015SD	TSP2020	570	690	300	280	69	34	127	85	34	122	71	131	63	10	83	62	32
2	ER2020LD	TSP2020	635	690	300	280	69	39	127	85	34	122	71	131	63	10	83	62	32
2	ER2020SD	TSP2020	650	690	300	280	69	39	127	85	34	122	71	131	63	10	83	62	32
2½	ER2025SD	TSP2030	680	890	320	324	79	39	148	100	36	134	80	152	74	10	102	68	36
3	ER2030SD	TSP2030	780	910	320	324	79	44	148	100	36	134	80	152	74	10	102	68	36
5	ER2050SD	TSP2050	900	910	297	400	53	47	169	118	46	144	81	178	70	10	104	88	54

SPECIFICATIONS

Capacity (tonne)	Hoist Model	Trolley Model	Lift Speed (ft/min)	Hoist Motor H.P.	Rated Current 575V (amps)	Headroom (in) Plain Trolley Mount	Minimum Radius for a Curve (mm)	Load Chain Code	Load Chain Falls	Ship Weight (lbs)	Weight per Additional 5 ft of Lift (lbs)
¼	ER2001HD	TSP2005	57/14	0.7/0.2	1.4/0.9	15.6	1100	KER2043	1	76	1.4
¼	ER2003SD	TSP2005	28/7	0.7/0.2	1.4/0.9	15.6	1100	KER2043	1	76	1.4
½	ER2005LD	TSP2005	14/4	0.7/0.2	1.4/0.9	16.3	1100	KER2060	1	93	2.7
½	ER2005SD	TSP2005	29/7	1.2/0.3	1.7/1.4	16.3	1100	KER2060	1	102	2.7
1	ER2010LD	TSP2010	14/4	1.2/0.3	1.7/1.4	18.5	1300	KER2077	1	138	4.5
1	ER2010SD	TSP2010	29/7	2.4/0.6	3.2/2.0	18.5	1300	KER2077	1	143	4.5
1½	ER2015SD	TSP2020	20/5	2.4/0.6	3.2/2.0	22.4	1500	KER2102	1	190	8
2	ER2020LD	TSP2020	15/4	2.4/0.6	3.2/2.0	25.0	1500	KER2102	1	195	8
2	ER2020SD	TSP2020	28/6	4.7/1.2	6.0/3.4	25.6	1500	KER2102	1	241	8
2½	ER2025SD	TSP2030	22/5	4.7/1.2	6.0/3.4	26.8	1700	KER2112	1	283	9.5
3	ER2030SD	TSP2030	18/4	4.7/1.2	6.0/3.4	32.7	1700	KER2102	2	292	16
5	ER2050SD	TSP2050	11/2	4.7/1.2	6.0/3.4	35.4	2300	KER2112	2	403	19

ER2 Adjustable 2-Speed Hoist - Geared Trolley Mount

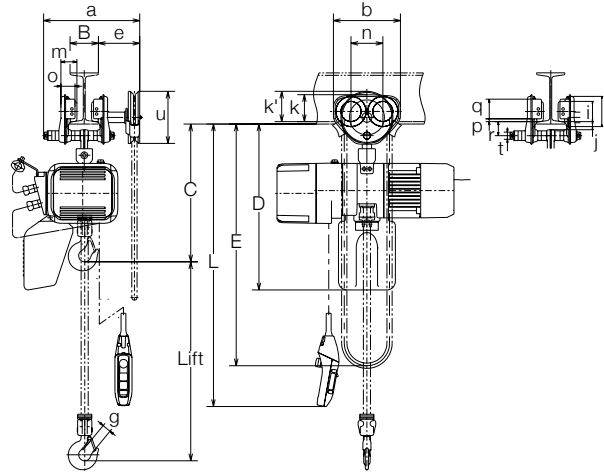

220
VOLTS

440
VOLTS

VFD
EQUIPPED

DIMENSIONS (mm)

Capacity (tonne)	Hoist Model	Trolley Model	C	D	a	b	e	g	h	i	j	k	k'	m	n	o	p	q	r	t	u
1/8	ER2001IH	TSG2010	415	490	345	236	152	27	106	71	28	95	107	56	112	50	10	69	50	25	183
1/4	ER2003IS	TSG2010	415	490	345	236	152	27	106	71	28	95	107	56	112	50	10	69	50	25	183
1/2	ER2005IL	TSG2010	435	550	345	236	152	27	106	71	28	95	107	56	112	50	10	69	50	25	183
1/2	ER2005IS	TSG2010	435	550	345	236	152	27	106	71	28	95	107	56	112	50	10	69	50	25	183
1	ER2010IL	TSG2010	470	590	345	236	152	31	106	71	28	95	107	56	112	50	10	69	50	25	183
1	ER2010IS	TSG2010	470	590	345	236	152	31	106	71	28	95	107	56	112	50	10	69	50	25	183
1 1/2	ER2015IS	TSG2020	570	690	358	280	154	34	127	85	34	112	109	71	131	63	10	83	62	32	183
2	ER2020IL	TSG2020	635	690	385	280	154	39	127	85	34	112	109	71	131	63	10	83	62	32	183
2	ER2020IS	TSG2020	635	690	385	280	154	39	127	85	34	112	109	71	131	63	10	83	62	32	183
2 1/2	ER2025IS	TSG2030	680	890	398	324	157	39	148	100	36	134	115	80	152	74	10	102	68	35	183
3	ER2030IS	TSG2030	780	910	398	324	157	44	148	100	36	134	115	80	152	74	10	102	68	35	183
5	ER2050IS	TSG2050	900	910	401	400	156	47	169	118	46	144	131	81	178	70	10	104	88	54	183

SPECIFICATIONS

Capacity (tonne)	Hoist Model	Trolley Model	Lift Speed (ft/min)			Hoist Motor H.P.	Rated Current (amps)		Headroom (in) Geared Trolley Mount	Minimum Radius for a Curve (mm)	Load Chain Code	Load Chain Falls	Ship Weight (lbs)	Weight per Additional 5 ft of Lift (lbs)
			Preset (6:1)	Max	Min		220V	440V						
1/8	ER2001IH	TSG2010	55/9	55	4.6	0.75	3.6	1.8	16.3	1300	KER2043	1	87	1.4
1/4	ER2003IS	TSG2010	36/6	36	3.0	0.75	3.6	1.8	16.3	1300	KER2043	1	87	1.4
1/2	ER2005IL	TSG2010	15/2.5	15	1.3	0.75	3.6	1.8	17.1	1300	KER2060	1	95	2.7
1/2	ER2005IS	TSG2010	28/5	28	2.4	1.2	5.1	2.7	17.1	1300	KER2060	1	104	2.7
1	ER2010IL	TSG2010	14/2.5	14	1.2	1.2	5.1	2.7	18.5	1300	KER2077	1	126	4.5
1	ER2010IS	TSG2010	27/4.5	27	2.3	2.4	9.1	4.5	18.5	1300	KER2077	1	142	4.5
1 1/2	ER2015IS	TSG2020	17/3	17	1.5	2.4	9.1	4.5	22.4	1500	KER2102	1	201	8
2	ER2020IL	TSG2020	14/2.5	14	1.2	2.4	9.1	4.5	25	1500	KER2102	1	203	8
2	ER2020IS	TSG2020	27/4.5	27	2.3	4.7	17.3	8.3	25.6	1500	KER2102	1	238	8
2 1/2	ER2025IS	TSG2030	22/3.5	22	1.8	4.7	17.3	8.3	26.8	1700	KER2112	1	278	9.5
3	ER2030IS	TSG2030	17/3	17	1.4	4.7	17.3	8.3	32.7	1700	KER2102	2	289	16
5	ER2050IS	TSG2050	11/2	11	0.9	4.7	17.3	8.3	35.4	2300	KER2112	2	454	19

ER2 Dual Speed Hoist - Geared Trolley Mount

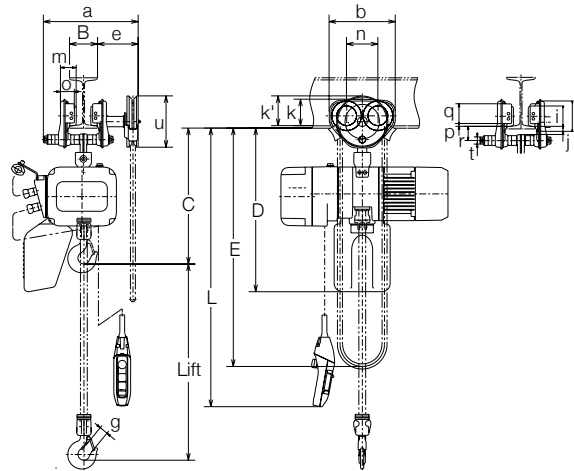

575
VOLTS

DIMENSIONS (mm)

Capacity (tonne)	Hoist Model	Trolley Model	C	D	a	b	e	g	h	i	j	k	k'	m	n	o	p	q	r	t	u
¼	ER2001HD	TSG2010	415	490	345	236	152	27	106	71	28	95	107	56	112	50	10	69	50	25	183
¼	ER2003SD	TSG2010	415	490	345	236	152	27	106	71	28	95	107	56	112	50	10	69	50	25	183
½	ER2005LD	TSG2010	435	550	345	236	152	27	106	71	28	95	107	56	112	50	10	69	50	25	183
½	ER2005SD	TSG2010	435	550	345	236	152	27	106	71	28	95	107	56	112	50	10	69	50	25	183
1	ER2010LD	TSG2010	470	590	345	236	152	31	106	71	28	95	107	56	112	50	10	69	50	25	183
1	ER2010SD	TSG2010	470	590	345	236	152	31	106	71	28	95	107	56	112	50	10	69	50	25	183
1½	ER2015SD	TSG2020	570	690	358	280	154	34	127	85	34	112	109	71	131	63	10	83	62	32	183
2	ER2020LD	TSG2020	635	690	385	280	154	39	127	85	34	112	109	71	131	63	10	83	62	32	183
2	ER2020SD	TSG2020	635	690	385	280	154	39	127	85	34	112	109	71	131	63	10	83	62	32	183
2½	ER2025SD	TSG2030	680	890	398	324	157	39	148	100	36	134	115	80	152	74	10	102	68	35	183
3	ER2030SD	TSG2030	780	910	398	324	157	44	148	100	36	134	115	80	152	74	10	102	68	35	183
5	ER2050SD	TSG2050	900	910	401	400	156	47	169	118	46	144	131	81	178	70	10	104	88	54	183

SPECIFICATIONS

Capacity (tonne)	Hoist Model	Trolley Model	Lift Speed (ft/min)	Hoist Motor H.P.	Rated Current 575V (amps)	Headroom (in) Geared Trolley Mount	Minimum Radius for a Curve (mm)	Load Chain Code	Load Chain Falls	Ship Weight (lbs)	Weight per Additional 5 ft of Lift (lbs)
¼	ER2001HD	TSG2010	57/14	0.7/0.2	1.4/0.9	16.3	1300	KER2043	1	93	1.4
¼	ER2003SD	TSG2010	28/7	0.7/0.2	1.4/0.9	16.3	1300	KER2043	1	93	1.4
½	ER2005LD	TSG2010	14/4	0.7/0.2	1.4/0.9	17.1	1300	KER2060	1	110	2.7
½	ER2005SD	TSG2010	29/7	1.2/0.3	1.7/1.4	17.1	1300	KER2060	1	119	2.7
1	ER2010LD	TSG2010	14/4	1.2/0.3	1.7/1.4	18.5	1300	KER2077	1	147	4.5
1	ER2010SD	TSG2010	29/7	2.4/0.6	3.2/2.0	18.5	1300	KER2077	1	152	4.5
1½	ER2015SD	TSG2020	20/5	2.4/0.6	3.2/2.0	22.4	1500	KER2102	1	201	8
2	ER2020LD	TSG2020	15/4	2.4/0.6	3.2/2.0	25	1500	KER2102	1	206	8
2	ER2020SD	TSG2020	28/6	4.7/1.2	6.0/3.4	25.6	1500	KER2102	1	252	8
2½	ER2025SD	TSG2030	22/5	4.7/1.2	6.0/3.4	26.8	1700	KER2112	1	292	9.5
3	ER2030SD	TSG2030	18/4	4.7/1.2	6.0/3.4	32.7	1700	KER2102	2	301	16
5	ER2050SD	TSG2050	11/2	4.7/1.2	6.0/3.4	35.4	2300	KER2112	2	461	19

ER2 Adjustable 2-Speed Hoist - Single-Speed Motorized Trolley

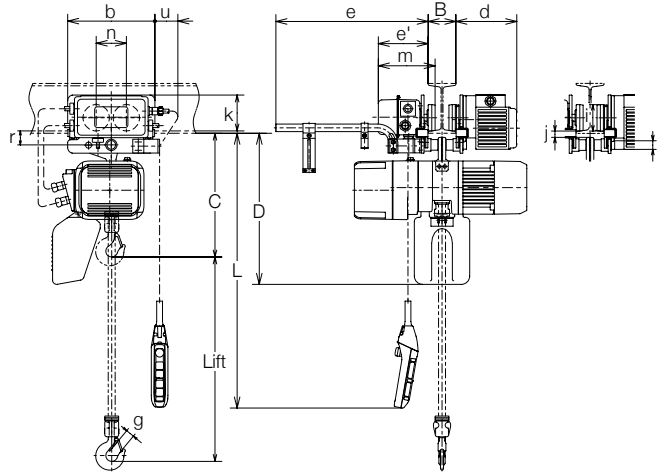

220
VOLTS

440
VOLTS

VFD
EQUIPPED

DIMENSIONS (mm)

Capacity (tonne)	Hoist & Trolley Model	C	D	b	d	e	e'	g	i	j	k	m	n	r	t	u
1/8	ER2M001IH	375	450	315	220	515	179	27	95	22	130	205	109	51	31	83
1/4	ER2M003IS	375	450	315	220	515	179	27	95	22	130	205	109	51	31	83
1/2	ER2M005IL	395	510	315	220	515	179	27	95	22	130	205	109	51	31	83
1/2	ER2M005IS	395	510	315	220	515	179	27	95	22	130	205	109	51	31	83
1	ER2M010IL	435	550	315	220	515	179	31	95	22	130	205	109	51	31	83
1	ER2M010IS	435	550	315	220	515	179	31	95	22	130	205	109	51	31	83
1 1/2	ER2M015IS	505	630	325	225	520	184	34	110	27	125	212	118	60	36	76
2	ER2M020IL	570	630	325	225	520	184	39	110	27	125	212	118	60	36	76
2	ER2M020IS	585	630	325	225	520	184	39	110	27	125	212	118	60	36	76
2 1/2	ER2M025IS	620	830	340	226	521	186	39	125	29	131	215	132	68	43	70
3	ER2M030IS	765	900	340	226	521	186	44	125	29	131	215	132	68	43	70
5	ER2M050IS	900	910	400	281	528	192	47	140	44	145	233	150	86	54	56

SPECIFICATIONS

Capacity (tonne)	Hoist & Trolley Model	Speed (ft/min)		Hoist Motor H.P.	Rated Current (amps)		Headroom (in) Lug Mount Only	Minimum Radius for a Curve (mm)	Load Chain Code	Load Chain Falls	Ship Weight (lbs)	Weight per Additional 5 ft of Lif (lbs)
		Hoist Lifting	Trolley Traversing		220V	440V						
1/8	ER2M001IH	55/9	40 or 80	0.75	6.8	3.4	14.8	800	KER2043	1	124	1.4
1/4	ER2M003IS	36/6	40 or 80	0.75	6.8	3.4	14.8	800	KER2043	1	124	1.4
1/2	ER2M005IL	15/2.5	40 or 80	0.75	6.8	3.4	15.6	800	KER2060	1	134	2.7
1/2	ER2M005IS	28/5	40 or 80	1.2	8.3	4.3	15.6	800	KER2060	1	143	2.7
1	ER2M010IL	14/2.5	40 or 80	1.2	8.3	4.3	17	800	KER2077	1	163	4.5
1	ER2M010IS	27/4.5	40 or 80	2.4	12.3	6.1	17	800	KER2077	1	178	4.5
1 1/2	ER2M015IS	17/3	40 or 80	2.4	12.3	6.1	20	800	KER2102	1	239	8
2	ER2M020IL	14/2.5	40 or 80	2.4	12.3	6.1	22	800	KER2102	1	241	8
2	ER2M020IS	27/4.5	40 or 80	4.7	20.5	9.9	23	800	KER2102	1	276	8
2 1/2	ER2M025IS	22/3.5	40 or 80	4.7	20.5	9.9	24.4	1000	KER2112	1	318	9.5
3	ER2M030IS	17/3	40 or 80	4.7	20.5	9.9	30	1000	KER2102	2	327	16
5	ER2M050IS	11/2	40 or 80	4.7	20.5	9.9	33	1800	KER2112	2	430	19

ER2 Dual Speed Hoist - Single-Speed Motorized Trolley



575
VOLTS

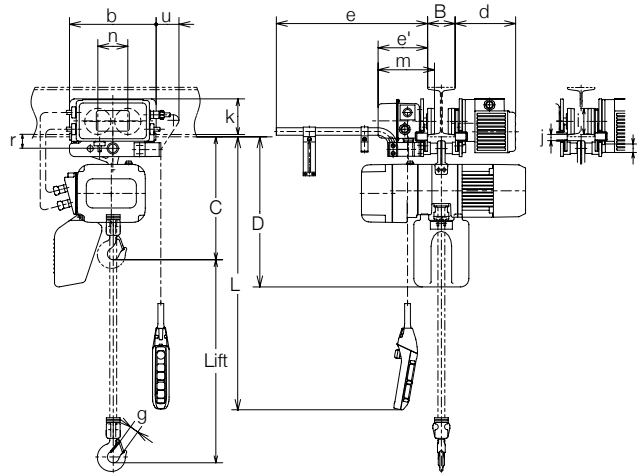

DIMENSIONS (mm)

Capacity (tonne)	Hoist & Trolley Model	C	D	b	d	e	e'	g	i	j	k	m	n	r	t	u
1/8	ER2M001HD	375	450	315	268	515	179	27	95	22	130	205	109	51	31	83
1/4	ER2M003SD	375	450	315	268	515	179	27	95	22	130	205	109	51	31	83
1/2	ER2M005LD	395	510	315	268	515	179	27	95	22	130	205	109	51	31	83
1/2	ER2M005SD	395	510	315	268	515	179	27	95	22	130	205	109	51	31	83
1	ER2M010LD	435	550	315	268	515	179	31	95	22	130	205	109	51	31	83
1	ER2M010SD	435	550	315	268	515	179	31	95	22	130	205	109	51	31	83
1 1/2	ER2M015SD	505	630	325	273	520	184	34	110	27	125	212	118	60	36	76
2	ER2M020LD	570	630	325	273	520	184	39	110	27	125	212	118	60	36	76
2	ER2M020SD	585	630	325	273	520	184	39	110	27	125	212	118	60	36	76
2 1/2	ER2M025SD	620	830	340	274	521	186	39	125	29	131	215	132	68	43	70
3	ER2M030SD	765	900	340	274	521	186	44	125	29	131	215	132	68	43	70
5	ER2M050SD	900	910	400	281	528	192	47	140	44	145	233	150	86	54	56

SPECIFICATIONS

Capacity (tonne)	Hoist & Trolley Model	Speed (ft/min)		Hoist Motor H.P.	Rated Current 575V (amps)	Headroom (in) Lug Mount Only	Minimum Radius for a Curve (mm)	Load Chain Code	Load Chain Falls	Ship Weight (lbs)	Weight per Additional 5 ft of Lift (lbs)
		Hoist Lifting	Trolley Traversing								
1/8	ER2M001HD	57/14	40 or 80	0.7/0.2	2.5/2.0	14.8	800	KER2043	1	143	1.4
1/4	ER2M003SD	28/7	40 or 80	0.7/0.2	2.5/2.0	14.8	800	KER2043	1	143	1.4
1/2	ER2M005LD	14/4	40 or 80	0.7/0.2	2.5/2.0	15.6	800	KER2060	1	158	2.7
1/2	ER2M005SD	29/7	40 or 80	1.2/0.3	2.8/2.5	15.6	800	KER2060	1	170	2.7
1	ER2M010LD	14/4	40 or 80	1.2/0.3	2.8/2.5	17	800	KER2077	1	198	4.5
1	ER2M010SD	29/7	40 or 80	2.4/0.6	4.3/3.1	17	800	KER2077	1	203	4.5
1 1/2	ER2M015SD	20/5	40 or 80	2.4/0.6	4.3/3.1	20	800	KER2102	1	255	8
2	ER2M020LD	15/4	40 or 80	2.4/0.6	4.3/3.1	22	800	KER2102	1	259	8
2	ER2M020SD	28/6	40 or 80	4.7/1.2	7.1/4.5	23	800	KER2102	1	308	8
2 1/2	ER2M025SD	22/5	40 or 80	4.7/1.2	7.1/4.5	24.4	1000	KER2112	1	348	9.5
3	ER2M030SD	18/4	40 or 80	4.7/1.2	7.1/4.5	30	1000	KER2102	2	359	16
5	ER2M050SD	11/2	40 or 80	4.7/1.2	7.1/4.5	33	1800	KER2112	2	460	19

ER2 Adjustable 2-Speed Hoist - Adjustable 2-Speed Motorized Trolley



220
VOLTS

440
VOLTS

VFD
EQUIPPED

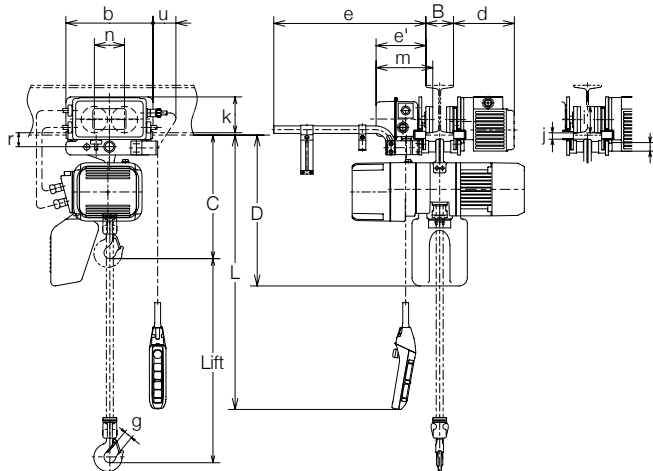

DIMENSIONS (mm)

Capacity (tonne)	Hoist & Trolley Model	C	D	b	d	e	e'	g	i	j	k	m	n	r	t	u
1/8	ER2MI001IH	375	450	315	220	515	179	27	95	22	130	205	109	51	31	83
1/4	ER2MI003IS	375	450	315	220	515	179	27	95	22	130	205	109	51	31	83
1/2	ER2MI005IL	395	510	315	220	515	179	27	95	22	130	205	109	51	31	83
1/2	ER2MI005IS	395	510	315	220	515	179	27	95	22	130	205	109	51	31	83
1	ER2MI010IL	435	550	315	220	515	179	31	95	22	130	205	109	51	31	83
1	ER2MI010IS	435	550	315	220	515	179	31	95	22	130	205	109	51	31	83
1 1/2	ER2MI015IS	505	630	325	225	520	184	34	110	27	125	212	118	60	36	76
2	ER2MI020IL	570	630	325	225	520	184	39	110	27	125	212	118	60	36	76
2	ER2MI020IS	585	630	325	225	520	184	39	110	27	125	212	118	60	36	76
2 1/2	ER2MI025IS	620	830	340	226	521	186	39	125	29	131	215	132	68	43	70
3	ER2MI030IS	765	900	340	226	521	186	44	125	29	131	215	132	68	43	70
5	ER2MI050IS	900	910	400	281	528	192	47	140	44	145	233	150	86	54	56

SPECIFICATIONS

Capacity (tonne)	Hoist & Trolley Model	Preset Speed (ft/min)		Hoist Motor H.P.	Rated Current (amps)		Headroom (in) Lug Mount Only	Minimum Radius for a Curve (mm)	Load Chain Code	Load Chain Falls	Ship Weight (lbs)	Weight per Additional 5 ft of Lift (lbs)
		Hoist Lifting	Trolley Traversing		220V	440V						
1/8	ER2MI001IH	55/9	80/13	0.75	7	3.5	14.8	800	KER2043	1	126	1.4
1/4	ER2MI003IS	36/6	80/13	0.75	7	3.5	14.8	800	KER2043	1	126	1.4
1/2	ER2MI005IL	15/2.5	80/13	0.75	7	3.5	15.6	800	KER2060	1	138	2.7
1/2	ER2MI005IS	28/5	80/13	1.2	8.5	4.4	15.6	800	KER2060	1	147	2.7
1	ER2MI010IL	14/2.5	80/13	1.2	8.5	4.4	17	800	KER2077	1	167	4.5
1	ER2MI010IS	27/4.5	80/13	2.4	12.5	6.2	17	800	KER2077	1	183	4.5
1 1/2	ER2MI015IS	17/3	80/13	2.4	12.5	6.2	20	800	KER2102	1	238	8
2	ER2MI020IL	14/2.5	80/13	2.4	12.5	6.2	22	800	KER2102	1	241	8
2	ER2MI020IS	27/4.5	80/13	4.7	20.7	10	23	800	KER2102	1	280	8
2 1/2	ER2MI025IS	22/3.5	80/13	4.7	20.7	10	24.4	1000	KER2112	1	329	9.5
3	ER2MI030IS	17/3	80/13	4.4	20.7	10	30	1000	KER2102	2	334	16
5	ER2MI050IS	11/2	80/13	4.7	20.7	11	33	1800	KER2112	2	436	19

ER2 Dual Speed Hoist - Dual Speed Motorized Trolley



575
VOLTS

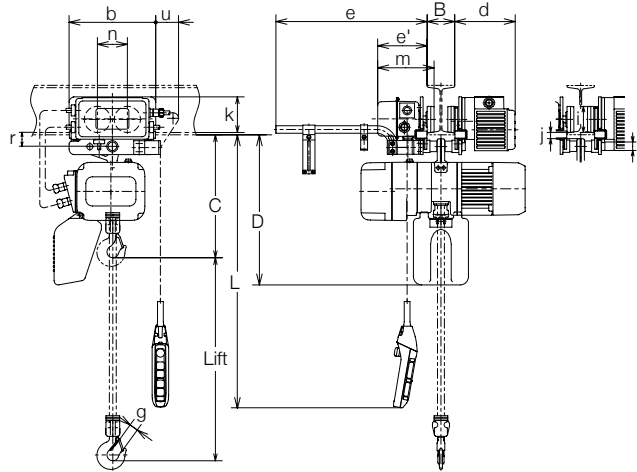

DIMENSIONS (mm)

Capacity (tonne)	Hoist & Trolley Model	C	D	b	d	e	e'	g	i	j	k	m	n	r	t	u
1/8	ER2MD001HD	375	450	315	268	515	179	27	95	22	130	205	109	51	31	83
1/4	ER2MD003SD	375	450	315	268	515	179	27	95	22	130	205	109	51	31	83
1/2	ER2MD005LD	395	510	315	268	515	179	27	95	22	130	205	109	51	31	83
1/2	ER2MD005SD	395	510	315	268	515	179	27	95	22	130	205	109	51	31	83
1	ER2MD010LD	435	550	315	268	515	179	31	95	22	130	205	109	51	31	83
1	ER2MD010SD	435	550	315	268	515	179	31	95	22	130	205	109	51	31	83
1 1/2	ER2MD015SD	505	630	325	273	520	184	34	110	27	125	212	118	60	36	76
2	ER2MD020LD	570	630	325	273	520	184	39	110	27	125	212	118	60	36	76
2	ER2MD020SD	585	630	325	273	520	184	39	110	27	125	212	118	60	36	76
2 1/2	ER2MD025SD	620	830	340	274	521	186	39	125	29	131	215	132	68	43	70
3	ER2MD030SD	765	900	340	274	521	186	44	125	29	131	215	132	68	43	70
5	ER2MD050SD	900	910	400	281	528	192	47	140	44	145	233	150	86	54	56

SPECIFICATIONS

Capacity (tonne)	Hoist & Trolley Model	Speed (ft/min)		Hoist Motor H.P.	Rated Current 575V (amps)	Headroom (in) Lug Mount Only	Minimum Radius for a Curve (mm)	Load Chain Code	Load Chain Falls	Ship Weight (lbs)	Weight per Additional 5 ft of Lift (lbs)
		Hoist Lifting	Trolley Traversing								
1/8	ER2MD001HD	57/14	80/40	0.7/0.2	2.5/1.7	14.8	800	KER2043	1	143	1.4
1/4	ER2MD003SD	28/7	80/40	0.7/0.2	2.5/1.7	14.8	800	KER2043	1	143	1.4
1/2	ER2MD005LD	14/4	80/40	0.7/0.2	2.5/1.7	15.6	800	KER2060	1	158	2.7
1/2	ER2MD005SD	29/7	80/40	1.2/0.3	2.8/2.2	15.6	800	KER2060	1	170	2.7
1	ER2MD010LD	14/4	80/40	1.2/0.3	2.8/2.2	17	800	KER2077	1	198	4.5
1	ER2MD010SD	29/7	80/40	2.4/0.6	4.3/2.8	17	800	KER2077	1	203	4.5
1 1/2	ER2MD015SD	20/5	80/40	2.4/0.6	4.3/2.8	20	800	KER2102	1	255	8
2	ER2MD020LD	15/4	80/40	2.4/0.6	4.3/2.8	22.4	800	KER2102	1	259	8
2	ER2MD020SD	28/6	80/40	4.7/1.2	7.1/4.2	23	800	KER2102	1	308	8
2 1/2	ER2MD025SD	22/5	80/40	4.7/1.2	7.3/4.5	24.4	1000	KER2112	1	348	9.5
3	ER2MD030SD	18/4	80/40	4.7/1.2	7.3/4.5	30	1000	KER2102	2	359	16
5	ER2MD050SD	11/2	80/40	4.7/1.2	7.3/4.5	33	1800	KER2112	2	460	19

EFS Series Electric Chain Hoists

1/4 to 2 metric tonne capacity, single phase (115V), proven reliability

KITO EFS Series Electric Chain Hoists are engineered for daily use in shop, farm, or light industry. EFS chain hoists feature advanced hoist technology, easy serviceability, and industry-leading quality.



FEATURES

- Load-bearing parts are only stressed to 20% of their limit at rated capacity
- Abrasion resistant, case-hardened, nickel-plated load chain is made from heat-treated alloy steel, ideal for corrosive environments
- Forged carbon steel hook design will not fracture under excessive load
- Advanced fail-safe pull rotor brake is electrically activated and requires no adjustment
- Spur gears immersed in oil bath ensure quiet, smooth operation and long life
- Unique chain guide design for smooth chain travel
- Slip clutch protects the hoist against over-travel and over-load damage
- 360° swivel bottom hook with built-in bearing, for easy positioning
- Weathertight construction resists dust and water
- High capacity condensers for long life
- Tested to 125% of rated capacity

Duty Ratings	Single Speed
ASME Class	H3
Max. Starts / hr	150
%ED	35
Short Time Rating	15 min

STANDARDS

- CSA Electrical Certification
- ASME B30.16 Safety Standard
- ASME HST-1 Performance Standard
- Grade 80, Case Hardened Chain
- IP55 Environmental Protection

OPTIONS

- Chain bag to keep chain clean and out of the way
- Custom lift lengths to suit your requirements
- Plain or Geared trolley mount for improved load control (p. 35)

EFS Single-Speed Hoist - Hook Mount



115
VOLTS

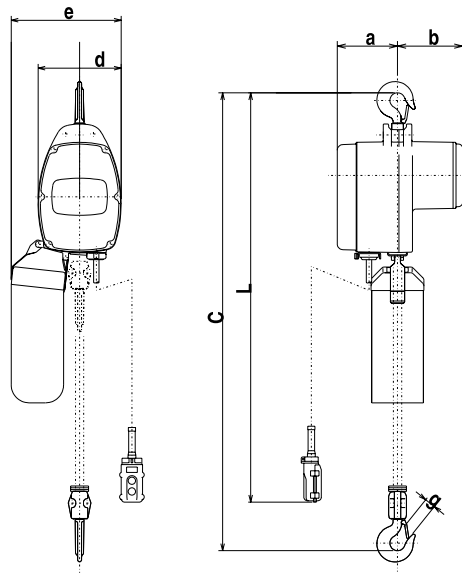

DIMENSIONS (mm)

Capacity (tonne)	Model	C	a	b	d	e	g
¼	EFS003S	508	242	152	178	279	29
½	EFS005L	552	242	152	178	279	29
½	EFS005S	559	224	171	222	387	29
1	EFS010L	635	224	171	222	387	32
1	EFS010S	629	224	191	235	413	32
2	EFS020L	800	224	191	254	432	38

SPECIFICATIONS

Capacity (tonne)	Model	Standard Lift (ft)	Max. Lift (ft)	Lift Speed (ft/min)	Hoist Motor H.P.	Rated Current 115V (amps)	Headroom (in)			Load Chain Code	Load Chain Falls	Ship Weight (lbs)	Weight per Additional 5 ft of Lift (lbs)
							Hook Mount Only	Plain Trolley	Geared Trolley				
¼	EFS003S	10	50	15	0.33	6.8	20	19.7	20.7	KER050	1	70	2
½	EFS005L	10	50	7	0.33	6.8	21.75	21	22	KER050	2	80	4
½	EFS005S	10	50	14	0.53	11.8	21.75	22	22	KER063	1	100	3
1	EFS010L	10	50	7	0.53	11.8	25	25	25	KER063	2	110	6
1	EFS010S	10	50	9	0.73	12.1	23.6	25	25	KER071	1	135	4
2	EFS020L	10	50	5	0.73	12.1	31.5	31	31	KER071	2	150	8

ED Series Electric Chain Hoists

100 to 480 kgs capacity, single phase (115V) high speed portable hoist



KITO ED Series Electric Chain Hoists are engineered for light weight, high-speed lifting with the flexibility of variable speeds. ED hoists are small enough to be portable, and they feature advanced hoist technology, easy serviceability, and industry-leading quality.

FEATURES

- Load-bearing parts are only stressed to 20% of their limit at rated capacity
- Abrasion resistant, case-hardened load chain is made from heat-treated alloy steel for high, uniform strength
- Plated chain for corrosion resistance
- Forged carbon steel hook design will not fracture under excessive load
- Double braking system includes both mechanical and regenerative brakes for added safety
- Spur gears immersed in oil bath ensure quiet, smooth operation and long life
- Unique chain guide design for smooth chain travel
- Slip clutch protects the hoist against over travel and overload damage
- 360° swivel bottom hook with built-in bearing, for easy positioning
- Weathertight construction resists dust and water
- Variable high speeds up to 44 ft/min – use the best lift speed for the job
- Compact and lightweight design is ideal for use in close quarters – small enough to be portable
- Low voltage pendant control for your safety
- Tested to 125% of rated capacity

Duty Ratings	Single Speed
ASME Class	H3
Max. Starts / hr	180
%ED	35
Short Time Rating	15 min

STANDARDS

- CSA Electrical Certification
- ASME B30.16 Safety Standard
- ASME HST-1 Performance Standard
- Grade 80, Case Hardened Chain
- IP44 Environmental Protection
- DC Motor Type

OPTIONS

- Dual speed units for increased productivity
- Ergonomic cylinder control for easy one-handed operation
- Chain bag to keep chain clean and out of the way
- Custom lift lengths to suit your requirements
- Plain trolley mount for improved load control (p. 35)



115
VOLTS

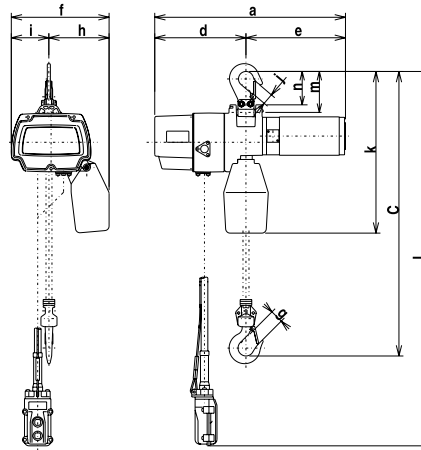

DIMENSIONS (mm)

Capacity (tonne)	Model	C	a	d	e	f	h	i	g	j	k	m	n
100 kg	EDL10S	300	371	187	184	200	120	80	27	25	340	92	73
240 kg	EDL24S	325	428	205	223	219	135	84	27	25	362	92	73
480 kg	EDL48S	520	428	205	223	229	155	74	24	24	454	149	----
100 kg	EDL10ST	300	371	187	184	200	120	80	27	25	340	92	73
240 kg	EDL24ST	325	428	205	223	219	135	84	27	25	362	92	73
480 kg	EDL48ST	520	428	205	223	229	155	74	24	24	454	149	----
100 kg	EDCL10SD	925	371	187	187	200	120	80	27	25	340	92	73
240 kg	EDCL24SD	955	428	205	223	219	135	84	27	25	362	92	73

SPECIFICATIONS

Capacity (tonne)	Model	Standard Lift (ft)	Max. Lift (ft)	Lift Speed (ft/min)	Hoist Motor H.P.	Rated Current 115V (amps)	Headroom (in)				Load Chain Code	Load Chain Falls	Ship Weight (lbs)	Weight per Additional 5 ft of Lift (lbs)	
							Hook Mount Only	Plain Trolley		Geared Trolley					
								Hook	Lug	Hook					Lug
EDL High Speed, Portable, Pendant Control, Hook Mount															
100 kg	EDL10S	10	20	43	0.4	5	12	----	9	----	----	KED040	1	25	2
240 kg	EDL24S	10	100	44	0.8	10	13	----	10	----	----	KED040	1	36	2
480 kg	EDL48S	10	50	22	0.8	10	21	23.4	----	24	----	KED040	2	49	4
EDL Dual Speed / High Speed, Portable, Pendant Control, Hook Mount															
100 kg	EDL10ST	10	20	43/10	0.4	5	12	----	9	----	----	KED040	1	27	2
240 kg	EDL24ST	10	65	44/10	0.8	10	13	----	10	----	----	KED040	1	37	2
480 kg	EDL48ST	10	32	22/6.5	0.8	10	21	23.4	----	24	----	KED040	2	49	4
EDCL Cylinder Control, Dual Speed / High Speed, Portable, Hook Mount															
100 kg	EDCL10SD	6	6	43/10	0.4	5	36	----	TBD	----	----	KED040	1	31	----
240 kg	EDCL24SD	6	6	44/10	0.8	10	38	----	TBD	----	----	KED040	1	45	----

TCR Series Air Powered Chain Hoists

1/4 to 25 tonne capacity, accurate, reliable hoist



The TCR series of air hoists feature a host of advantages to increase your productivity. Compact and highly durable, these quiet-to-operate air hoists perform fine feathering movements and precise load spotting without electrical hazard.

FEATURES

- Load-bearing parts are only stressed to 20% of their limit at rated capacity
- Abrasion resistant, case-hardened, nickel-plated load chain is made from heat-treated alloy steel for high, uniform strength
- Forged carbon steel hook design will not fracture under excessive load
- Reliable non-asbestos, self adjusting brake
- Built-in load limiter automatically stops lifting when load is over the rated capacity on 1/2 tonne and above
- Upper and lower limit switch prevent over-travel in up or down direction
- 360° swivel bottom hook with built-in bearing, for easy positioning
- Weathertight construction resists dust and water, reliable in harsh environments
- Fine feathering movement with precision starting and stopping
- Quiet operation with external muffler
- 100% duty cycle multi-vane motor with filter/lubricator installed
- Full range variable speed control for increased productivity
- Filter/Lubricator included with each unit
- Test Load: 125% of rated capacity

STANDARDS

- ASME B30.16 Safety Standard
- ASME HST-5 Performance Standard
- Grade 80, Case Hardened Chain
- 80.5 dBA at 1 metre
- 90 PSI Pressure

OPTIONS

- Pendant or cord control to meet your needs
- Chain bag to keep chain clean and out of the way
- Custom lift lengths to suit your requirements
- Plain or Geared trolley mount for improved load control (p. 35)

TCR Variable Speed Hoist - Hook Mount

1/4 TONNE - MINI CHAIN HOIST



DIMENSIONS (mm)

Capacity (tonne)	Model	C	A	B	D	E	H	J
TCR Manipulator Control - Hook Suspension								
¼	TCR250M	837	269	112	89	66	373	23
TCR Pendant Control - Hook Suspension								
¼	TCR250P	305	269	112	89	66	373	23
TCR Cord Control - Hook Suspension								
¼	TCR250C	305	231	112	89	66	373	23

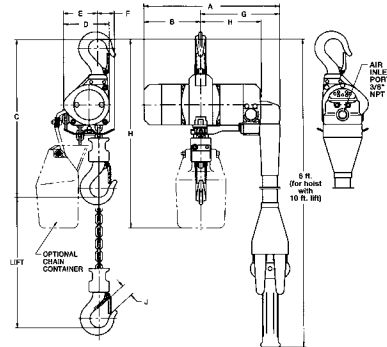

SPECIFICATIONS

Capacity (tonne)	Model	Standard Lift (ft)	Max. Lift (ft)		Speeds (90 PSI - ft/min)				Headroom (in)				Load Chain Code	Load Chain Falls	Ship Weight (lbs)	Weight per Additional 5 ft of Lift (lbs)	
					Up		Down		Plain Trolley		Geared Trolley						
			Chain	Pendant	with Load	w/o Load	with Load	w/o Load	Hook Mount Only	Hook	Lug	Hook					Lug
TCR Manipulator Control - Hook Suspension																	
¼	TCR250M	6	6	6	26	55	54	41	33	36	31.7	36	----	KED040	1	24	----
TCR Pendant Control - Hook Suspension																	
¼	TCR250P	10	130	20	27	55	54	41	12	15	10.7	15	----	KED040	1	16	4
½	TCR500P	10	130	20	33	62	52	43	18.25	22	18.6	22	18.6	KER063	1	68	4
1	TCR1000P2	10	65	20	16	31	27	21	20.5	24.6	21.3	24.6	21.3	KER063	2	76	8
1	TCR1000P	10	130	20	19	34	31	21	18.5	22.6	19.2	22.6	19.2	KER071	1	74	5
2	TCR2000P2	10	65	20	10	17	15	10	22.75	28	23	28	22.9	KER071	2	87	10
3	TCR3000P	10	130	25	9	17	13	10	22.25	28.4	21.6	28.4	21.6	KER112	1	151	11
6	TCR6000P2	10	65	25	5	8	7	5	27	----	29.5	----	29.5	KER112	2	197	22
10	TCR10000P2	10	50	16	5.1	7.2	7.6	5.9	35	----	----	----	----	LCTCR10	2	476	19
25	TCR25000P2	10	50	16	1.8	2.1	2.2	1.6	56.7	----	----	----	----	LCTCR25	2	1082	35
TCR Cord Control - Hook Suspension																	
¼	TCR250C	10	130	----	30	61	57	45	12	15	10.7	15	----	KED040	1	16	4
½	TCR500C	10	130	----	33	62	52	43	18.25	22	18.6	22	18.6	KER063	1	68	4
1	TCR1000C2	10	65	----	16	31	27	21	18.25	24.6	21.3	24.6	21.3	KER063	2	76	8
1	TCR1000C	10	130	----	19	34	31	21	18.5	22.6	19.2	22.6	19.2	KER071	1	74	5
2	TCR2000C2	10	65	----	10	17	15	10	22.75	28	23	28	22.9	KER071	2	87	10
3	TCR3000C	10	130	----	9	17	13	10	22.25	28.4	21.6	28.4	21.6	KER112	1	151	11
6	TCR6000C2	10	65	----	5	8	7	5	27	----	29.5	----	29.5	KER112	2	197	22
10	TCR10000C2	10	50	----	5.1	7.2	7.6	5.9	35	----	----	----	----	LCTCR10	2	465	19
25	TCR25000C2	10	50	----	1.8	2.1	2.2	1.6	56.7	----	----	----	----	LCTCR25	2	1074	35

TCR Variable Speed Hoist - Hook Mount

½ to 6 Metric Tonne
Pendant Control

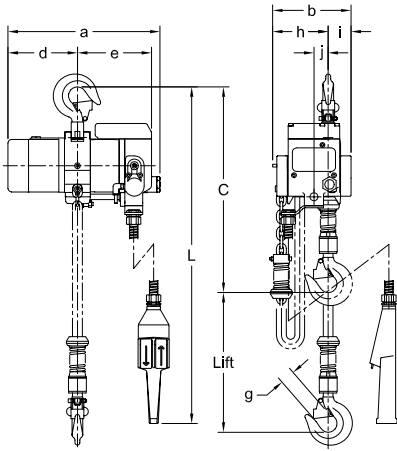

½ to 6 Metric Tonne
Cord Control

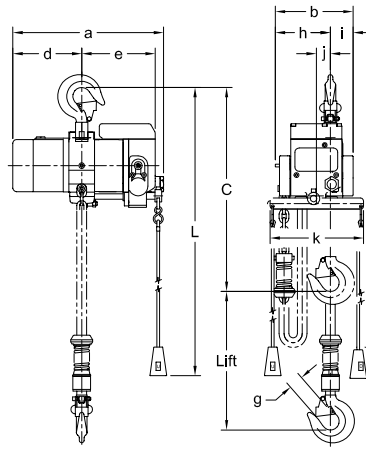

10 to 25 Metric Tonne
Pendant Control

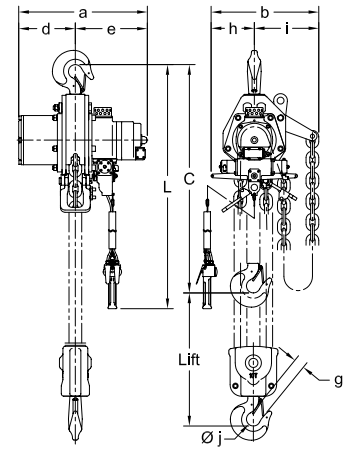

DIMENSIONS (mm)

Capacity (tonne)	Model	c	a	b	d	e	g	h	i	j	k
Pendant Control - Hook Suspension											
½	TCR500P	462	340	175	155	168	28	124	51	33	----
1	TCR1000P2	519	340	185	155	168	28	150	38	56	----
1	TCR1000P	466	340	175	155	168	28	124	51	33	----
2	TCR2000P2	580	340	193	155	168	28	152	41	58	----
3	TCR3000P	563	450	226	203	229	33	48	175	43	----
6	TCR6000P2	690	450	282	203	229	43	64	221	86	----
10	TCR10000P2	889	551	467	246	305	41	188	279	61	----
25	TCR25000P2	1440	699	475	363	335	79	163	312	124	----
Cord Control - Hook Suspension											
½	TCR500C	462	340	175	155	168	28	124	51	33	211
1	TCR1000C2	519	340	185	155	168	28	150	38	56	211
1	TCR1000C	466	340	175	155	168	28	124	51	33	211
2	TCR2000C2	580	340	193	155	168	28	152	41	58	211
3	TCR3000C	563	450	226	203	229	33	48	175	43	211
6	TCR6000C2	690	450	282	203	229	43	64	221	86	211
10	TCR10000C2	889	551	467	246	305	41	188	279	61	----
25	TCR25000C2	1440	699	475	363	335	79	163	312	124	----

CF Series Manual Chain Hoists

1/2 to 3 metric tonne capacity, economical, smooth-running hoists



KITO CF Series Manual Chain Hoists are built with quality components to provide years of reliable service. CF manual chain hoists feature heat-treated components, sealed bearings, and industry-leading quality.

FEATURES

- At rated capacity, load-bearing parts are only stressed to 25% of their limit
- Abrasion resistant load chain is made from heat-treated alloy steel for high, uniform strength
- Forged carbon steel hook design will not fracture under excessive load
- Safe, reliable mechanical brake activates instantly, holds the load securely
- Compact design for lightweight portability
- Articulating top hook allows you to properly centre the load
- Sealed gears and brake protected against damage from dust and water
- Maintenance-free sealed bearings increase reliability and reduce the pull required to lift loads
- Heat treated load bearing parts are hardened for long, trouble-free life
- Die cast aluminum housing for lightweight portability
- Test Load: 150% of rated capacity

STANDARDS

- ASME B30.16 Safety Standard
- ASME HST-2 Performance Standard
- Grade 100, Case Hardened Chain

OPTIONS

- Nickel-diffused chain for corrosive environments
- Custom lift lengths to suit your requirements

DIMENSIONS (mm)

Capacity (tonne)	Model	C	b	d	g
½	CF005	325	150	2.5	27
1	CF010	370	174	2.5	29
1½	CF015	440	203	2.5	34
2	CF020	540	204	3	36
3	CF030	590	240	3	42.5

½ to 1½ Metric Tonne

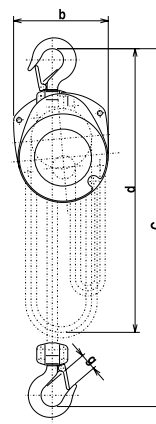

2 to 3 Metric Tonne

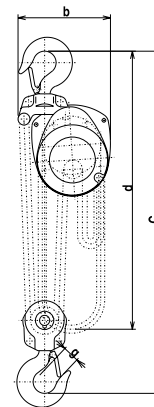

SPECIFICATIONS

Capacity (tonne)	Model	Standard Lift (ft)	Hand Pull to Lift Full Load (kg)	Chain Pulled to Lift Load one meter (meters)	Hook Mount Headroom (in)	Load Chain Code	Load Chain Falls	Hand Chain Code	Hand Chain Falls	Ship Weight (lbs)	Weight per Additional 5 ft of Lift (lbs)
½	CF005	8	30	19	13	KCF050	1	KHCF050	2	24	5
1	CF010	8	36	31	14.5	KCF063	1	KHCF050	2	31	6
1½	CF015	8	42	41	17.5	KCF071	1	KHCF050	2	42	7
2	CF020	10	40	63	20	KCF063	2	KHCF050	2	51	9
3	CF030	10	46	81	23	KCF071	2	KHCF050	2	68	11

M3CB Series Manual Chain Hoists

1/2 to 50 metric tonne capacity, high-capacity, lightweight hoist



KITO M3 Series Manual Chain Hoists are built with premium-grade components for long life in the toughest industrial and contracting applications. M3 manual chain hoists are small and light, yet extremely durable, with industry-leading quality.

FEATURES

- At rated capacity, load-bearing parts are only stressed to 25% of their limit
- Abrasion resistant load chain is made from heat-treated alloy steel for high, uniform strength
- Forged carbon steel hook design will not fracture under excessive load
- Safe, reliable mechanical brake activates instantly, holds the load securely
- Compact design for lightweight portability
- Articulating top hook allows you to properly centre the load
- Sealed gears and brake protected against damage from dust and water
- Open load sheave allows easy inspection and cleaning without dismantling the unit
- Maintenance-free sealed bearings increase reliability and reduce the pull required to lift loads
- Heat treated load bearing parts are hardened for long, trouble-free life
- High-impact steel housing with similar weight to aluminum due to compact design
- Double reduction gearing requires minimum manual power to operate
- Double-pawl spring system for increased safety and reliability
- Test Load: 125% of rated capacity

STANDARDS

- ASME B30.16 Safety Standard
- ASME HST-2 Performance Standard
- Grade 100 Chain

OPTIONS

- Chain bag to keep chain clean and out of the way
- Slip clutch protects hoist from overloading
- Nickel-diffused chain for corrosive environments
- Custom lift lengths to suit your requirements
- Plain or Geared trolley mount for improved load control (p. 35)

M3CB Steel Body - Hook Mount

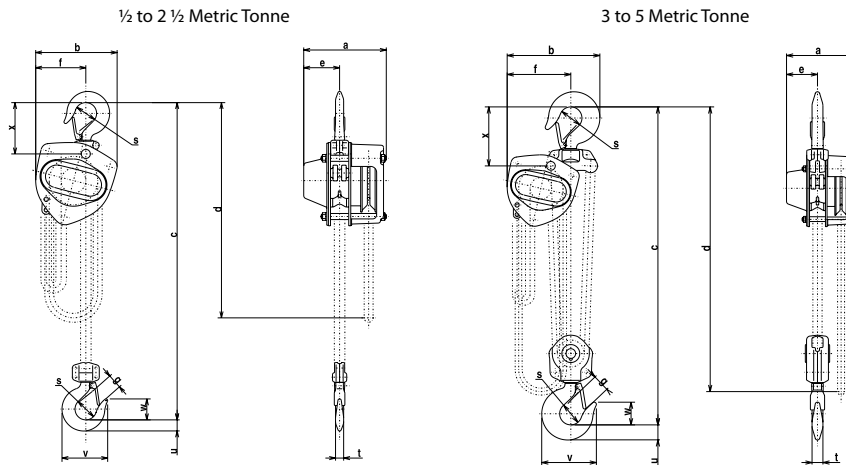

DIMENSIONS (mm)

Capacity (tonne)	Model	C	a	b	d	e	f	g	s	t	u	v	w	x
1/2	M3CB005	285	158	161	2.5	69	99	27	35.5	12.1	17	77	35	89
1	M3CB010	295	162	161	2.5	71	99	29	42.5	16	21.8	93	41	101
1 1/2	M3CB015	350	171	182	2.5	78	112	34	47.5	19.5	26.5	106	47	119
2	M3CB020	375	182	202	3	87	125	36	50	21.8	30	116	49	124
2 1/2	M3CB025	420	192	233	3	91	143	40	53	24.3	33.5	126	53	136
3	M3CB030	510	171	235	3.1	78	162	42.5	56	27.2	37.5	138	57	148
5	M3CB050	600	192	282	3.6	91	194	46.5	63	34.5	47.5	161	67.5	172

SPECIFICATIONS

Capacity (tonne)	Model	Standard Lift (ft)	Hand Pull to Lift Full Load (kg)	Chain Pulled to Lift Load one meter (meters)	Hook Mount Only	Headroom (in)				Load Chain Code	Load Chain Falls	Hand Chain Code	Hand Chain Falls	Ship Weight (lbs)	Weight per Additional 5 ft of Lift (lbs)
						Plain Trolley		Geared Trolley							
						Hook	Lug	Hook	Lug						
1/2	M3CB005	8	24	25	11.25	14.5	11.6	15	11.6	KCF050	1	KHCF050	2	23	5
1	M3CB010	8	29	43	11.75	15	12	15	12	KCF063	1	KHCF050	2	27	6
1 1/2	M3CB015	8	35	57	13.75	18.5	14	18.5	14	KCF071	1	KHCF050	2	33	7
2	M3CB020	10	36	70	14.75	19	15	19	15	KCB3080	1	KHCF050	2	47	8
2 1/2	M3CB025	10	33	99	16.5	22	17	22	17	KCB3090	1	KHCF050	2	60	9
3	M3CB030	10	36	114	20	26	21	26	21	KCF071	2	KHCF050	2	58	11
5	M3CB050	10	34	198	23.75	31	24	31	24	KCB3090	2	KHCF050	2	95	15

M3CB Steel Body - Hook Mount - Large Capacity

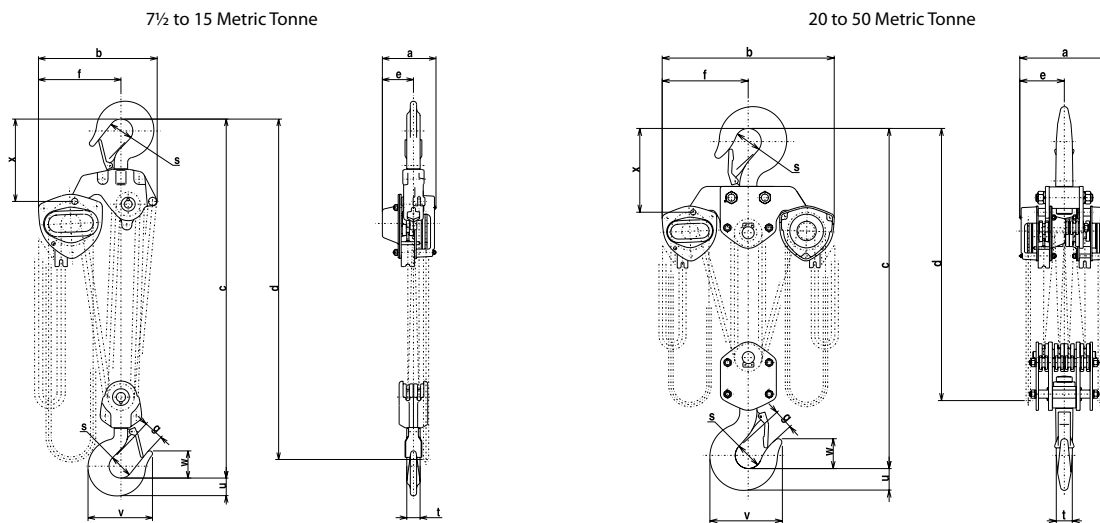

DIMENSIONS (mm)

Capacity (tonne)	Model	C	a	b	d	e	f	g	s	t	u	v	w	x
7½	M3CB075	770	192	373	4.2	91	253	72.5	85	47.5	63	231	97.5	275
10	M3CB100	760	192	438	4.2	111	308	72.5	85	47.5	63	231	97.5	295
15	M3CB150	1020	268	492	4.7	119	337	80	100	60	80	275	110	320
20	M3CB200	1180	374	746	4.8	187	373	81	110	67	90	301	125	351
30	M3CB300	1300	404	746	4.8	202	373	103	125	85	112	367	143	400
40	M3CB400	1480	502	760	4.9	251	380	96	145	123	133	412.5	182.5	445
50	M3CB500	1560	544	796	4.9	272	398	100	165	135	155	447.5	202.5	467

SPECIFICATIONS

Capacity (tonne)	Model	Hand Pull to Lift Full Load (kg)	Chain Pulled to Lift Load one meter (meters)	Headroom (in)				Load Chain Code	Load Chain Falls	Hand Chain Code	Hand Chain Falls	Ship Weight (lbs)	Weight per Additional 5 ft of Lift (lbs)	
				Hook Mount Only	Plain Trolley		Geared Trolley							
					Hook	Lug	Hook							Lug
7½	M3CB075	35	297	30.5	34.5	----	34.5	----	KCB3090	3	KHCF050	2	145	21
10	M3CB100	36	396	30	34	----	34	----	KCB3090	4	KHCF050	2	200	27
15	M3CB150	37	594	40.25	----	----	45	----	KCB3090	6	KHCF050	2	363	38
20	M3CB200	36 x 2	396 x 2	46.5	----	----	52	----	KCB3090	8	KHCF050	4	671	53
30	M3CB300	43 x 2	495 x 2	51.25	----	----	----	----	KCB3090	10	KHCF050	4	880	65
40	M3CB400	43 x 2	693 x 2	58.3	----	----	----	----	KCB3090	14	KHCF050	4	1386	88
50	M3CB500	49 x 2	792 x 2	61.5	----	----	----	----	KCB3090	16	KHCF050	4	1738	100

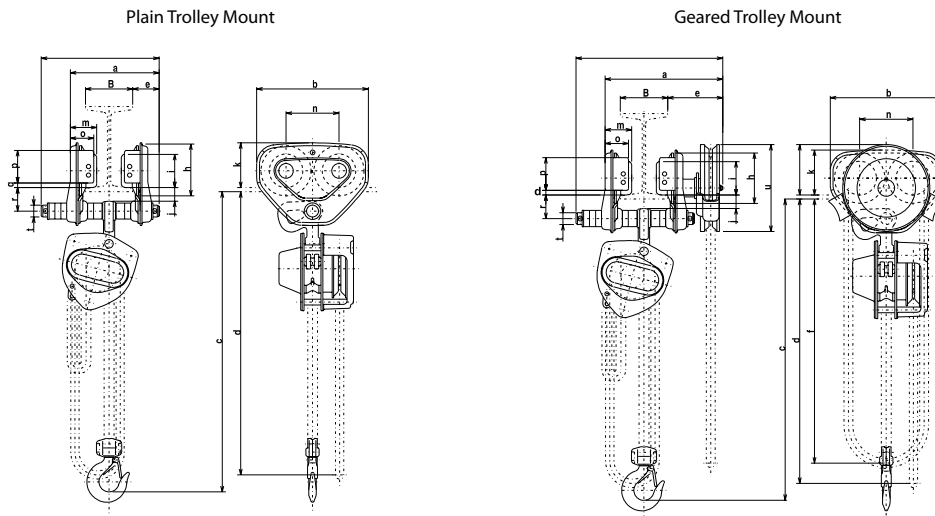

DIMENSIONS (mm)

Capacity (tonne)	Hoist Model	Trolley Model	a (max)	a1	C	b	d	e	f	h	i	j	k	k1	m	n	o	p	q	r	t	u
Plain Trolley Mount																						
½	M3CB005	TSP2005	173	204	295	182	2.5	46	2.2	82	60	19	76	106	47.5	84	42	54	10	38	22	183
1	M3CB010	TSP2010	215	249	305	236	2.5	56	2.2	106	71	28	95	106	56	112	50	69	10	50	25	183
1½	M3CB015	TSP2020	264	300	365	280	2.5	69	2.2	127	85	34	112	109	71	131	63	83	10	62	32	183
2	M3CB020	TSP2020	264	300	380	280	3	69	2.7	127	85	34	112	109	71	131	63	83	10	62	32	183
2½	M3CB025	TSP2030	280	320	435	324	3	79	2.7	148	100	36	134	114	80	152	74	102	10	68	36	183
3	M3CB030	TSP2030	280	320	535	324	3.1	79	2.7	148	100	36	134	114	80	152	74	102	10	68	36	183
5	M3CB050	TSP2050	273	297	660	400	3.6	53	3.2	169	118	47	144	131	81	178	70	104	10	88	54	183
Geared Trolley Mount																						
½	M3CB005	TSG2010	275	309	305	236	2.5	116	2.2	106	71	28	95	106	56	112	50	69	10	50	25	183
1	M3CB010	TSG2010	275	309	305	236	2.5	116	2.2	106	71	28	95	106	56	112	50	69	10	50	25	183
1½	M3CB015	TSG2020	349	385	365	280	2.5	154	2.2	127	85	34	112	109	71	131	63	83	10	62	32	183
2	M3CB020	TSG2020	349	385	380	280	3	154	2.7	127	85	34	112	109	71	131	63	83	10	62	32	183
2½	M3CB025	TSG2030	359	398	435	324	3	157	2.7	148	100	36	134	114	80	152	74	102	10	68	36	183
3	M3CB030	TSG2030	359	398	535	324	3.1	157	2.7	148	100	36	134	114	80	152	74	102	10	68	36	183
5	M3CB050	TSG2050	376	400	660	400	3.6	156	3.2	169	118	47	144	131	81	178	70	104	10	88	54	183
7½	M3CB075	TSG2100	443	523	870	492	4.3	178	3.7	185	155	53	170	165	120	196.5	104	89	8	153	70	214
10	M3CB100	TSG2100	443	523	860	492	4.3	178	3.7	185	155	53	170	165	120	196.5	104	89	8	153	70	214
15	M3CB150	TSG2200	576	540	1150	1012	4.8	178	4.2	185	155	62	170	165	120	716.5	104	89	8	203	80	214
20	M3CB200	TSG2200	576	540	1310	1012	4.9	178	4.2	185	155	62	170	165	120	716.5	104	89	8	203	80	214

CX Series Ultra Compact Manual Chain Hoists

1/4 metric tonne capacity, extremely lightweight and portable



KITO CX Series Mini-Manual Chain Hoist is suitable for work in tight quarters or wherever you need to lift a light load. The CX manual hoist features an ultra-compact size, easy operation and advanced safety mechanism for a unique combination of extreme portability, operation and safety.

FEATURES

- At rated capacity, load-bearing parts are only stressed to 25% of their limit.
- Advanced-design Overload Limiter is standard on the CX to enhance worker safety and protect the hoist against excessive overloading.
- Low hand-pull force for easy operation (15 kg pull force to lift rated load).
- Aluminum housing and ultra-compact design makes for reduced weight and size.
- Wide hook opening allows easy installation onto almost any reliable attachment point.
- Abrasion and corrosion resistant, plated load chain.
- Articulating top hook allows you to properly centre the load.
- Forged carbon steel hook design will not fracture under excessive load.
- Safety tip hook latch design is thicker for increased durability, and notched to securely engage the latch with the hook tip.
- Sealed gears and brake are protected against damage from dust and water.
- Test Load: 150% of rated capacity

STANDARDS

- ASME B30.16 Safety Standard
- ASME HST-2 Performance Standard
- Grade 100, Nickel Plated Chain

OPTIONS

- Carrying bag for easy portability and storage.
- Additional lifting heights available.

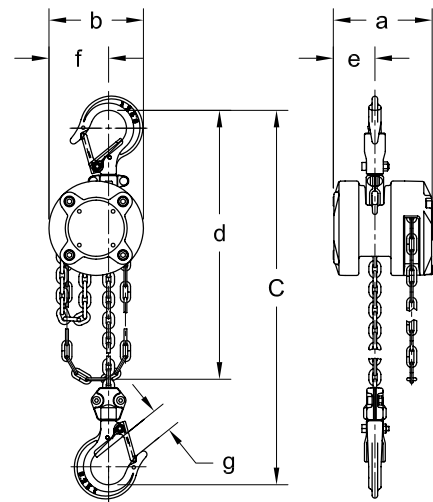

DIMENSIONS (mm)

Capacity (tonne)	Model	C	a	b	d	e	g	s	t
1/4	CX003	217	88	84	53	37	21	32	11

SPECIFICATIONS

Capacity (tonne)	Model	Standard Lift (ft)	Hand Pull to Lift Full Load (kg)	Chain Pulled to Lift Load one meter (meters)	Hook Mount Headroom (in)	Load Chain Code	Load Chain Falls	Hand Chain Code	Hand Chain Falls	Ship Weight (lbs)	Weight per Additional 5 ft of Lift (lbs)
1/4	CX003	8	15	34	8.6	KLX032	1	KHCX025	2	5.7	2

LX Series Lever Chain Hoists

1/4 and 1/2 metric tonne capacity, pocket-sized lever hoist



KITO LX Series Lever Hoists are suitable for work in tight quarters or elevated locations where fastening, fixing or positioning of light loads is required. LX lever hoists feature a low hand pull force for highly reliable lifting.

FEATURES

- At rated capacity, load-bearing parts are only stressed to 25% of their limit
- Abrasion and corrosion resistant, plated load chain
- Forged carbon steel hook design will not fracture under excessive load
- 360° handle rotation for a sure grip from any operating position
- Articulating top hook allows you to properly centre the load
- Safety tip hook latch design is thicker for increased durability, and notched to securely engage the latch with the hook tip
- Aluminum housing for reduced weight
- Sealed gears and brake are protected against damage from dust and water
- Free chain adjusting mechanism for quick and easy hook positioning
- Test Load: 125% of rated capacity

STANDARDS

- ASME B30.21 Safety Standard
- ASME HST-3 Performance Standard
- Grade 100 Chain

OPTIONS

- Carrying case that can be attached to your belt for added convenience (LX003)
- Custom lift lengths to suit your needs

DIMENSIONS (mm)

Capacity (tonne)	Model	C	D	a	b	e	g	s	t
¼	LX003	205	150	85.5	73.5	60	21	32	11
½	LX005	246	180	93	93	63	24.5	35.5	12

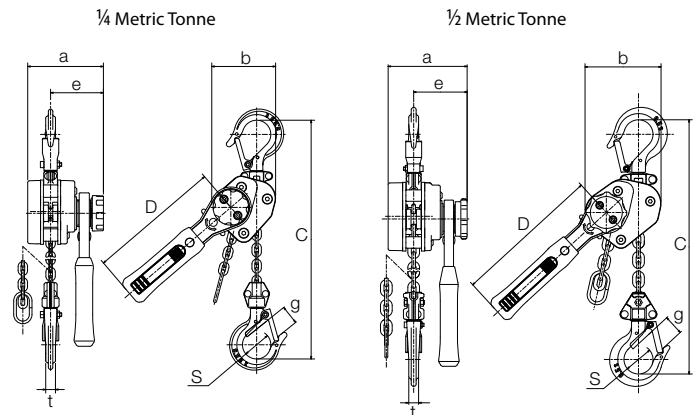

SPECIFICATIONS

Capacity (tonne)	Model	Standard Lift (ft)	Hand Pull to Lift Full Load (kg)	Headroom (in)	Handle Length (in)	Load Chain Code	Load Chain Falls	Ship Weight (lbs)	Weight per Additional 5 ft of Lift (lbs)
¼	LX003	3	20	8	6	KLX032	1	4	2
½	LX005	4	31	9.75	7	KLX043	1	6	2

L5LB Series Lever Chain Hoists

3/4 to 9 metric tonne capacity, tough, smooth-operating hoist



KITO L5 Series Lever Hoists are built with premium grade components for long life in demanding industrial and contracting applications. L5 lever hoists feature double-reduction gearing for reduced size and weight.

FEATURES

- At rated capacity, load-bearing parts are only stressed to 25% of their limit
- Patented induction hardening process on load bearing parts increases strength and rigidity of the frame
- Abrasion and corrosion resistant, nickel plated load chain made from heat-treated alloy steel for high, uniform strength
- Articulating top hook allows you to properly centre the load
- Forged carbon steel hook design will not fracture under excessive load
- Protective guard around the chain pin for enhanced safety
- Safety tip hook latch design is thicker for increased durability, and notched to securely engage with the hook tip
- Reliable weston-style mechanical brake design holds the load securely
- Five-start thread on brake ensures a level braking surface to ease load break-out
- Double-reduction gearing requires minimum manual power for operation
- Spring-loaded freewheel for quick and easy hook positioning
- Open load sheave allows easy inspection and cleaning without dismantling the unit
- 360° handle rotation for a sure grip from any operating position
- Compact design for lightweight portability
- High-impact steel housing has similar weight to aluminum due to compact design
- Sealed gears and brake are protected against damage from dust and water
- Cap nuts protect exposed bolts from damage
- Available in capacities of .75, 1.5, 2.5, 3, 6 and 9 metric tonnes
- Test Load: 125% of rated capacity

STANDARDS

- ASME B30.21 Safety Standard
- ASME HST-3 Performance Standard
- Grade 100, Nickel Plated Chain

OPTIONS

- Slip Clutch protects hoist in the event of an excessive overload
- Black Chain for heavy welding applications
- Custom lift lengths to suit your requirements

L5LB Steel Body - Lever Hoists

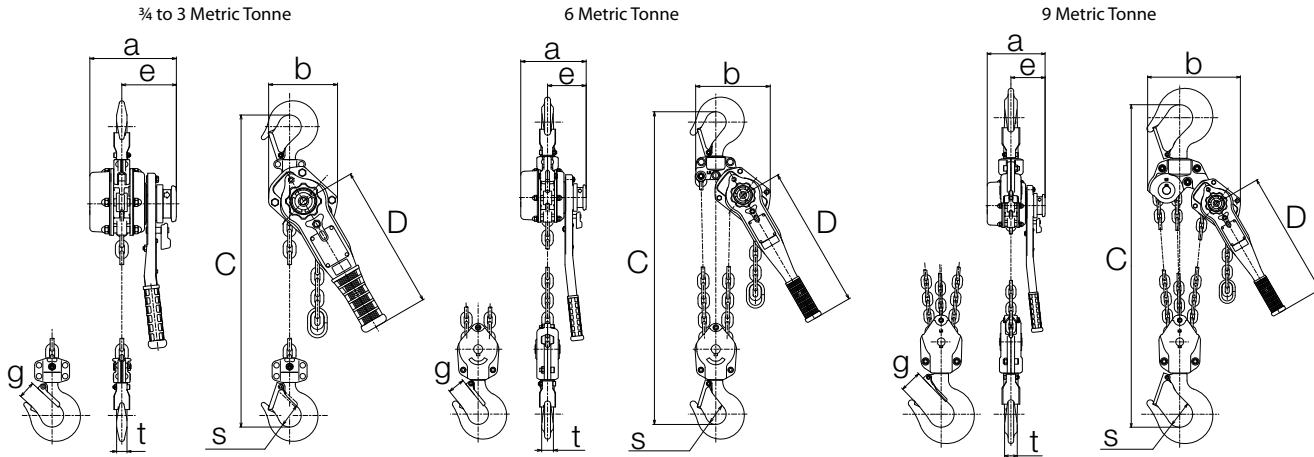

DIMENSIONS (mm)

Capacity (tonne)	Model	C	D	a	b	e	g	s	t
¾	L5LB008	280	245	144	119	97	23.5	35.5	14
1½	L5LB015	335	265	159	126	100	32	42.5	19
2½	L5LB025	375	265	173	150	102	36.5	47	21
3	L5LB030	395	415	190	159	112	39	50	24.5
6	L5LB060	540	415	190	217	112	50	60	34
9	L5LB090	680	415	190	304	112	72.5	85	41.5

SPECIFICATIONS

Capacity (tonne)	Model	Standard Lift (ft)	Hand Pull to Lift Full Load (kg)	Headroom (in)	Handle Length (in)	Load Chain Code	Load Chain Falls	Ship Weight (lbs)	Weight per Additional 5 ft of Lift (lbs)
¾	L5LB008	5	27	11	9.75	KLB5056	1	13	3
1½	L5LB015	5	32	13.25	10.5	KLB5071	1	18	4
2½	L5LB025	5	37	14.75	10.5	KLB5088	1	26	6
3	L5LB030	5	35	15.5	16.5	KLB5100	1	35	8
6	L5LB060	5	36	21.25	16.5	KLB5100	2	59	16
9	L5LB090	5	39	26.75	16.5	KLB5100	3	92	24

L5LB WITH OPTIONAL SLIP CLUTCH

Slip Clutch hoists make for safer worksites. This internal mechanism protects the hoist from damage in the event of an excessive overload, with no increase in size.

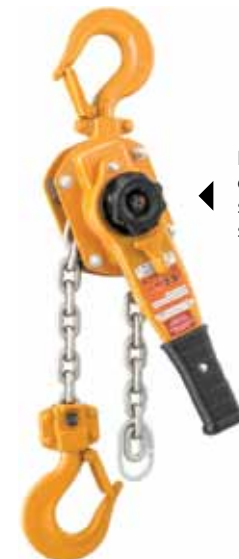

Black freewheel knob easily distinguishes the slip clutch unit from standard lever hoists.

T^S2 Series Manual Trolleys

1/2 to 20 metric tonne capacity, industrial quality, built for long life



Whether plain or geared, there's a trolley to fit every KITO hoist. The reliability, smoothness of operation, and safety of your hoist is dependent on the trolley. Be sure to choose KITO quality and safety for both the hoist and trolley.

FEATURES

- 1/2 to 20 tonne capacity allows you to choose the capacity that meets your needs
- At rated capacity, load-bearing parts are only stressed to 20% of their limit
- Heat treated steel wheels are hardened for long, trouble-free life
- Lifetime lubricated ball bearings increase reliability and reduce maintenance
- Adjustable to fit any beam—tapered or flat flanged, easily adapted for your shop or plant
- Low minimum radius for curved beams for smooth travel around tight curves
- Safety Lugs as standard

SPECIFICATIONS

Capacity (tonne)	Model	Min. Radius for Curve (mm)	Standard Flange (mm)			Standard Flange (in)			Standard Drop (ft)	Ship Weight (lbs)
			Standard	W20 Extension	W30 Extension	Standard	W20 Extension	W30 Extension		
Plain Trolley - with Safety Lugs										
1/2	TSP2005	1100	50 - 102	103 - 203	204 - 305	2 - 4"	4 - 8"	8 - 12"	----	10
1	TSP2010	1300	58 - 127	128 - 203	204 - 305	2.25 - 5"	5 - 8"	8 - 12"	----	18
2	TSP2020	1500	82 - 153	----	154 - 305	3.25 - 6"	----	6 - 12"	----	31
3	TSP2030	1700	82 - 153	----	154 - 305	3.25 - 6"	----	6 - 12"	----	51
5	TSP2050	2300	100 - 178	----	179 - 305	4 - 7"	----	7 - 12"	----	116
10	TSP2100	3000	150 - 220	----	221 - 305	6 - 8.5"	----	8.5 - 12"	----	220
Geared Trolley - with Safety Lugs										
1	TSG2010	1300	58 - 127	128 - 203	204 - 305	2.25 - 5"	5 - 8"	8 - 12"	8	27
2	TSG2020	1500	82 - 153	----	154 - 305	3.25 - 6"	----	6 - 12"	10	42
3	TSG2030	1700	82 - 153	----	154 - 305	3.25 - 6"	----	6 - 12"	10	60
5	TSG2050	2300	100 - 178	----	179 - 305	4 - 7"	----	7 - 12"	10	174
10	TSG2100	3000	150 - 220	----	221 - 305	6 - 8.5"	----	8.5 - 12"	12	300
20	TSG2200	----	150 - 220	----	221 - 305	6 - 8.5"	----	8.5 - 12"	12	440

TMH 1/4 TONNE - MINI TROLLEY - EXCLUSIVE FOR ED SERIES HOISTS



SPECIFICATIONS

Capacity (tonne)	Model	Min. Radius for Curve (mm)	Standard Flange		Ship Weight (lbs)
			(mm)	(in)	
1/4	TMH25	600	50 - 100	2 - 4"	5

MR2 Series Motorized Trolleys

1 to 20 metric tonne capacity, three phase, heavy duty



FEATURES

- Single Speed Trolleys from 1 to 20 tonne capacity allows you to choose the capacity that meets your needs
- Dual Speed Trolleys (575V) up to 5 tonne, for improved efficiency
- Adjustable 2-Speed Trolleys (220/440V) featuring a Variable Frequency Drive (VFD) for improved load control
- Heat treated steel wheels are hardened for long, trouble-free life
- Lifetime lubricated ball bearings increase reliability and reduce maintenance
- Adjustable to fit any beam – tapered or flat flanged, easily adapted for your shop or plant
- Safety Lugs as standard

SPECIFICATIONS

Capacity (tonne)	Model	Travel Speed (ft/min)	Min. Radius for Curve (mm)	Trolley Motor H.P.	Standard Flange (mm)			Standard Flange (in)			Ship Weight (lbs)
					Standard	W20 Extension	W30 Extension	Standard	W20 Extension	W30 Extension	
Single Speed Trolley for connection to Single Speed Hoist - Three Phase (220/440/575V)											
1	MR2010L	40	800	0.54	58 - 127	128 - 203	204 - 305	2.25 - 5"	5 - 8"	8 - 12"	66
1	MR2010S	80	800	0.54	58 - 127	128 - 203	204 - 305	2.25 - 5"	5 - 8"	8 - 12"	66
2	MR2020L	40	800	0.54	82 - 153	----	154 - 305	3.25 - 6"	----	6 - 12"	84
2	MR2020S	80	800	0.54	82 - 153	----	154 - 305	3.25 - 6"	----	6 - 12"	84
3	MR2030L	40	1000	0.54	82 - 153	----	154 - 305	3.25 - 6"	----	6 - 12"	106
3	MR2030S	80	1000	0.54	82 - 153	----	154 - 305	3.25 - 6"	----	6 - 12"	106
5	MR2050L	40	1800	1.0	100 - 178	----	179 - 305	4-7"	----	7 - 12"	154
5	MR2050S	80	1800	1.0	100 - 178	----	179 - 305	4-7"	----	7 - 12"	154
10	MR2100L	40	2500	1.0	178 - 221	----	140 - 221	5.5 - 8.7"	----	8.7 - 12"	216
20	MR2200L	40	----	1.0 x 3	178 - 221	----	140 - 221	5.5 - 8.7"	----	8.7 - 12"	433
Single-Speed Trolley for connection to Adj. 2 Speed/Dual Speed Hoist - Three Phase (220/440/575V)											
1	MR2010L □D	40	800	0.54	58 - 127	128 - 203	204 - 305	2.25 - 5"	5 - 8"	8 - 12"	66
1	MR2010S □D	80	800	0.54	58 - 127	128 - 203	204 - 305	2.25 - 5"	5 - 8"	8 - 12"	66
2	MR2020L □D	40	800	0.54	82 - 153	----	154 - 305	3.25 - 6"	----	6 - 12"	84
2	MR2020S □D	80	800	0.54	82 - 153	----	154 - 305	3.25 - 6"	----	6 - 12"	84
3	MR2030L □D	40	1000	0.54	82 - 153	----	154 - 305	3.25 - 6"	----	6 - 12"	106
3	MR2030S □D	80	1000	0.54	82 - 153	----	154 - 305	3.25 - 6"	----	6 - 12"	106
5	MR2050L □D	40	1800	1.0	100 - 178	----	179 - 305	4 - 7"	----	7 - 12"	154
5	MR2050S □D	80	1800	1.0	100 - 178	----	179 - 305	4 - 7"	----	7 - 12"	154
Adjustable 2 Speed Motorized Trolley for connection to Adj. 2 Speed Hoist - Three Phase (220/440V)											
1	MR2010IS	13 80	800	0.54	58 - 127	128 - 203	204 - 305	2.25 - 5"	5 - 8"	8 - 12"	70
2	MR2020IS	13 80	800	0.54	82 - 153	----	154 - 305	3.25 - 6"	----	6 - 12"	86
3	MR2030IS	13 80	1000	0.54	82 - 153	----	154 - 305	3.25 - 6"	----	6 - 12"	110
5	MR2050IS	13 80	1000	1.0	100 - 178	----	179 - 305	4 - 7"	----	7 - 12"	158
Dual Speed Motorized Trolley for connection to Dual Speed Hoist - Three Phase (575V)											
1	MR2010SD	40 80	800	0.54	58 - 127	128 - 203	204 - 305	2.25 - 5"	5 - 8"	8 - 12"	73
2	MR2020SD	40 80	800	0.54	82 - 153	----	154 - 305	3.25 - 6"	----	6 - 12"	90
3	MR2030SD	40 80	1000	0.54	82 - 153	----	154 - 305	3.25 - 6"	----	6 - 12"	112
5	MR2050SD	40 80	1000	1.0	100 - 178	----	179 - 305	4 - 7"	----	7 - 12"	163

WWW.KITO.CA
1 888 322 KITO (5486)

Call 1 888 322 KITO for further
information or assistance with
product selection

KITO is registered to the
ISO9001 quality standard

KITO Canada Inc.
309 - 3815 1st Ave.
Burnaby, BC V5C3V6

36 - 2400 Lucknow Drive
Mississauga, ON L5S1T9

All specifications, dimensions and drawings
are available at www.kito.ca

PRINTED IN CANADA | FL - ENG - 09

KITO
HOISTS & CRANES